



SC SERIES
SPECIFICATIONS:
3-JAW SCROLL CHUCK PLAIN BACK, SOLID JAWS.

1. Interchangeable utilization of internal and external hard jaws.
2. SC types feature economical and durable, suitable for mass production.
3. Gripping accuracy of 0.03mm (0.012inch) T.I.R..
4. The body is made of MEEHANITE. It is suitably used for high speed revolution and 3 times more durable than regular chucks.



SIC SERIES
SPECIFICATIONS:
4-JAW SCROLL CHUCK PLAIN BACK, SOLID JAWS.

1. Gripping of square or octagonal workpieces could fit into central line automatically.
2. SIC have high stability in gripping thin tube work piece.
3. The specification is the same as SC type.
4. The body is made of MEEHANITE. It is suitably used for high speed revolution and 3 times more durable than regular chucks.

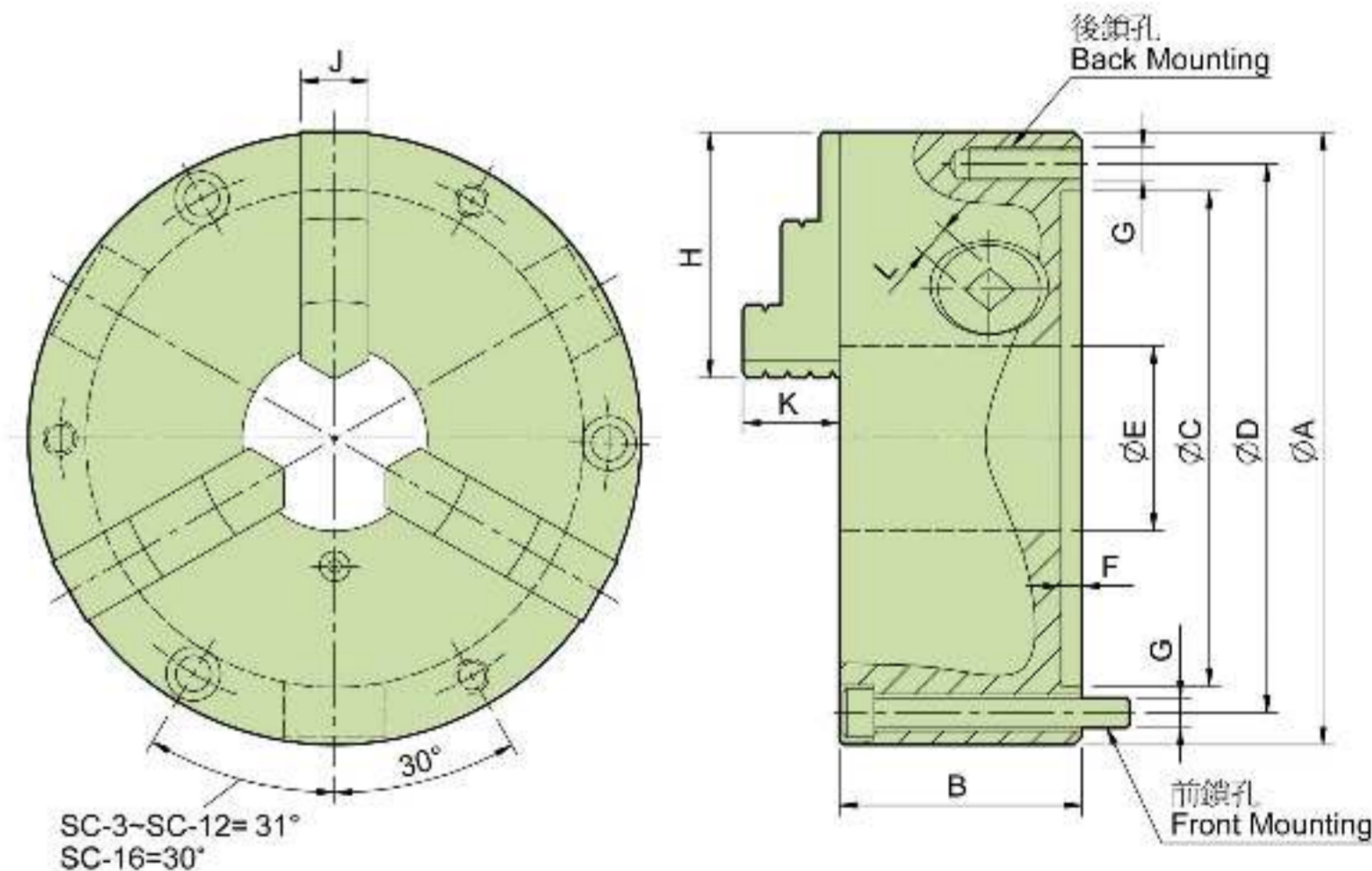
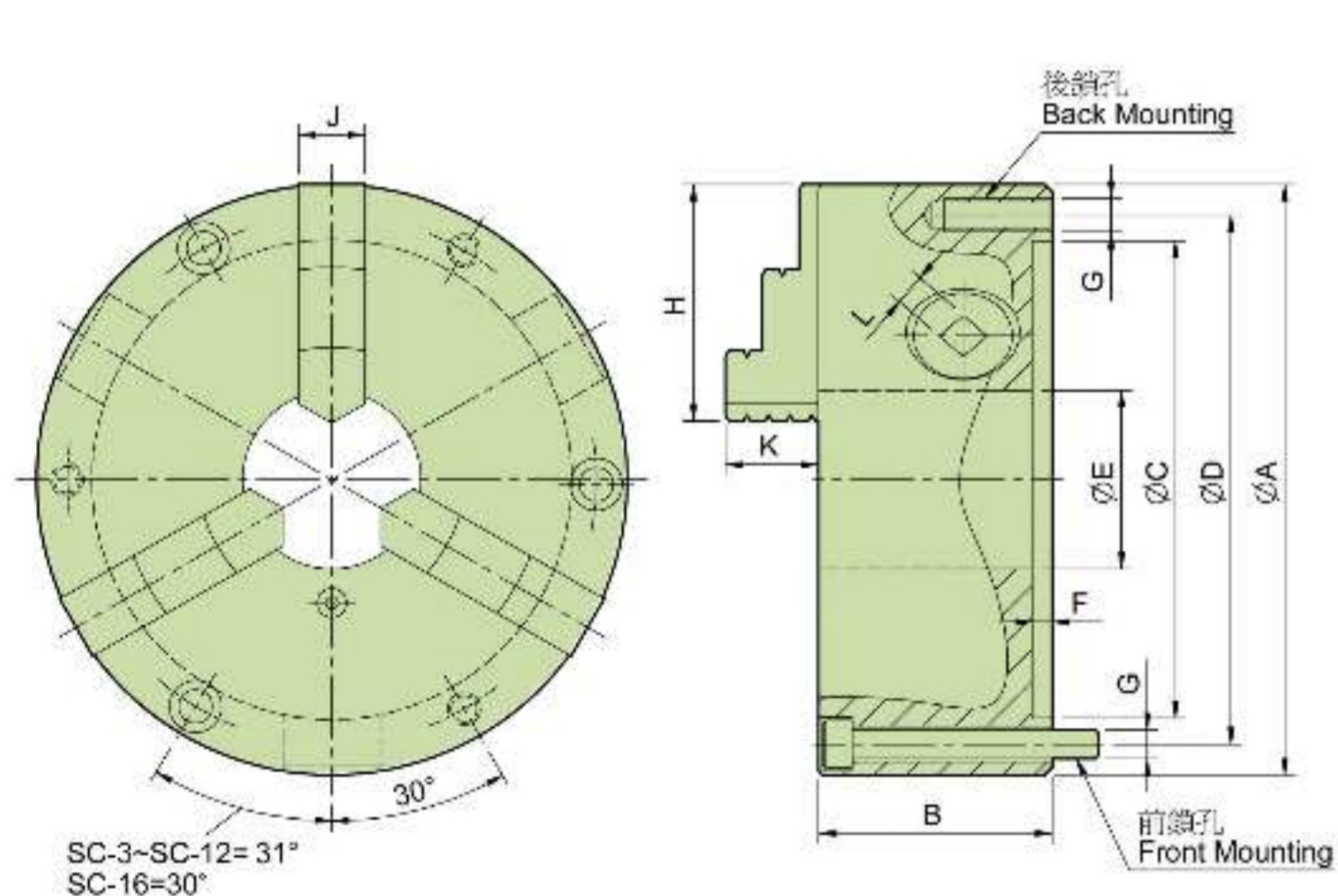

SPECIFICATIONS:

UNIT:mm

Model	Dim	A	B	C	D	E	F	G		H	J	K	L	Allowable Handle Torque (kgf·m)	Gripping Force (kgf)	Moment of Inertia I (kg·m ²)	Weight (kg)	Max. Speed (r.p.m.)	Gripping Range	
								Back	Front										O.D. range	I.D. range
SC-3	86	46	60	73	16	4	3-M6	3-M6x50	36	11	15	7	3.0	900	—	1.7	3500	φ2-φ70	φ24-φ64	
SC-4	112	60	80	95	24	4.8	3-M6	3-M6x70	42	14	16.6	8	4.5	1200	—	3.7	2500	φ3-φ95	φ23-φ84	
SC-5	132	60	100	115	32	4.8	3-M6	3-M6x70	50	16	20.3	8	6.5	1500	0.01	5.2	2500	φ3-φ110	φ33-φ100	
SC-6	167	87	130	147	45	5.5	3-M10	3-M10x70	83	19	23.7	10	9.0	3300	0.03	9.5	4300	φ4-φ160	φ49-φ150	
SC-7	182	76.5	155	172	58	5.5	3-M10	3-M10x60	77	21.5	28.4	11	11.0	3600	0.06	14.2	3500	φ4-φ180	φ56-φ170	
SC-8	200	76.5	160	176	58	5.5	3-M10	3-M10x60	77	21.5	28.4	11	11.0	3600	0.07	16	3200	φ4-φ190	φ62-φ180	
SC-9	232	84	190	210	70	8	3-M12	3-M12x90	87	24	35.6	12	15.0	3900	0.15	22.7	2900	φ5-φ220	φ62-φ210	
SC-10	273	87	230	250	89	8	3-M12	3-M12x90	98	28	39.5	12	19.5	4800	0.25	31.8	2500	φ6-φ260	φ73-φ250	
SC-12	310	96	260	285	105	7	3-M12	3-M12x110	110	30	45.6	14	21.0	5100	0.58	44.8	2200	φ10-φ300	φ86-φ290	
SC-16	405	122	345	375	160	8.7	—	6-M14x130	146	42	56.3	15	23.0	4500	1.75	102	1500	φ30-φ360	φ110-φ360	

SPECIFICATIONS:

UNIT:mm

Model	Dim	A	B	C	D	E	F	G		H	J	K	L	Allowable Handle Torque (kgf·m)	Gripping Force (kgf)	Moment of Inertia I (kg·m ²)	Weight (kg)	Max. Speed (r.p.m.)	Gripping Range	
								Back	Front										O.D. range	I.D. range
SIC-7	182	76.5	155	172	58	5.5	3-M10	—	77	21.5	29.4	11	11.0	3600	0.06	14.8	3500	φ4-φ180	φ56-φ170	
SIC-9	232	84	190	210	70	8	3-M12	—	87	24	35.6	12	15.0	3900	0.16	23.2	2900	φ5-φ220	φ62-φ210	
SIC-12	310	96	260	285	105	7	3-M12	—	110	30	45.6	14	21.0	5100	0.58	47	2200	φ10-φ300	φ86-φ290	
SIC-16	405	122	345	375	160	8.7	—	6-M14x130	146	42	56.3	15	23.0	4500	1.72	107	1500	φ30-φ360	φ110-φ360	



SK SERIES
SPECIFICATIONS:
3-JAW STRONG SCROLL CHUCK
PLAIN BACK, 2-PIECE JAWS.

- 1.SK types chucks have wider utilization range; hard jaws suitable for heavy cutting; soft jaws suitable for light and precision cutting.
- 2.Hard jaws could be used as internal jaws and external jaws.
- 3.Gripping accuracy of 0.03mm (0.012 inch) T.I.R.
- 4.The body is made of MEEHANITE. It is suitably used for high speed revolution and 3 times more durable than regular chucks.



SIK SERIES
SPECIFICATIONS:
4-JAW STRONG SCROLL CHUCK
PLAIN BACK, 2-PIECE JAWS.

- 1.Hard jaws are adopted for square for square or octagonal thin tube workpieces machining.
- 2.Soft jaws could grip rectangular workpiece after being unisotropic machined.
- 3.The specification is the same as SK type.
- 4.The body is made of MEEHANITE. It is suitably used for high speed revolution and 3 times more durable than regular chucks.

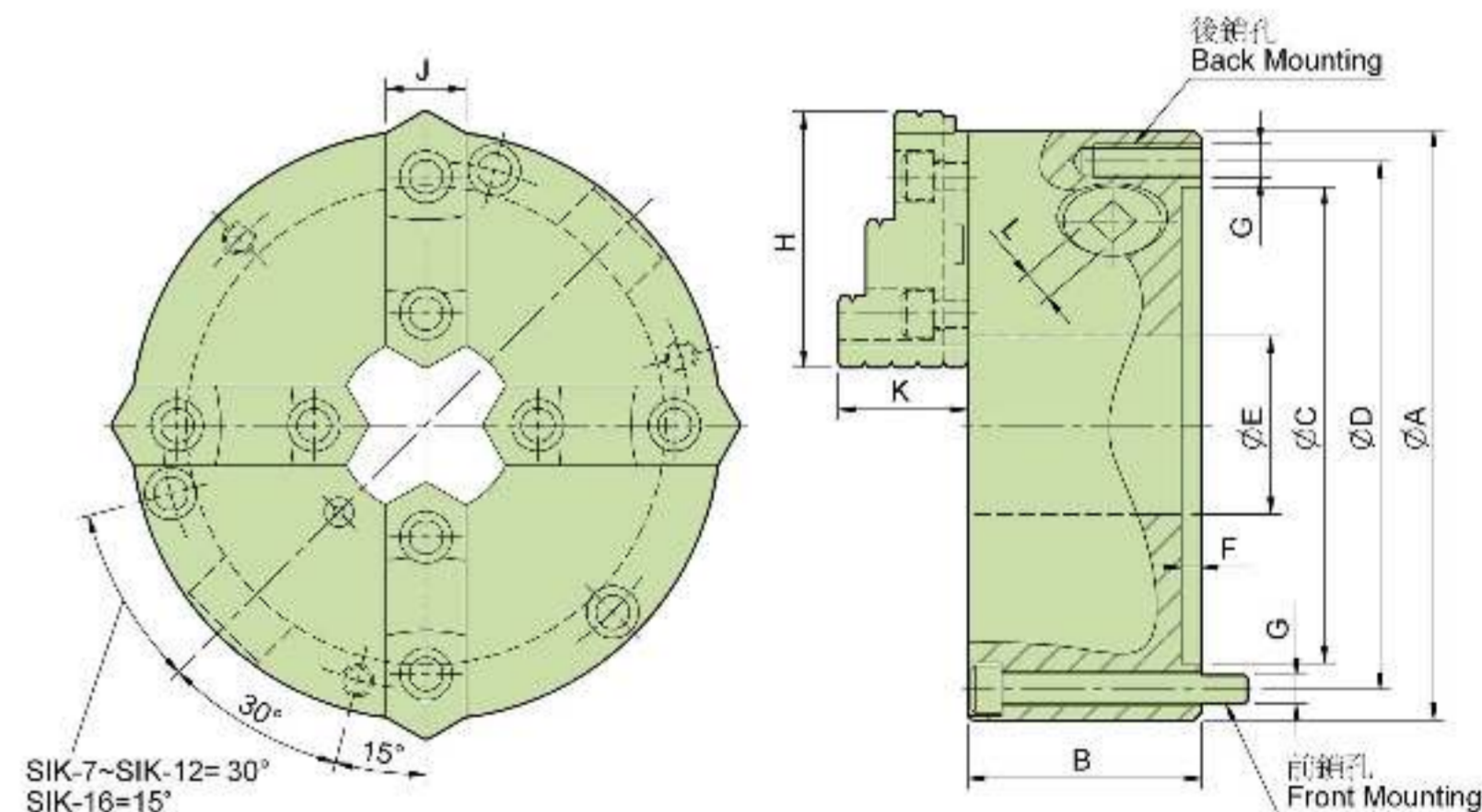
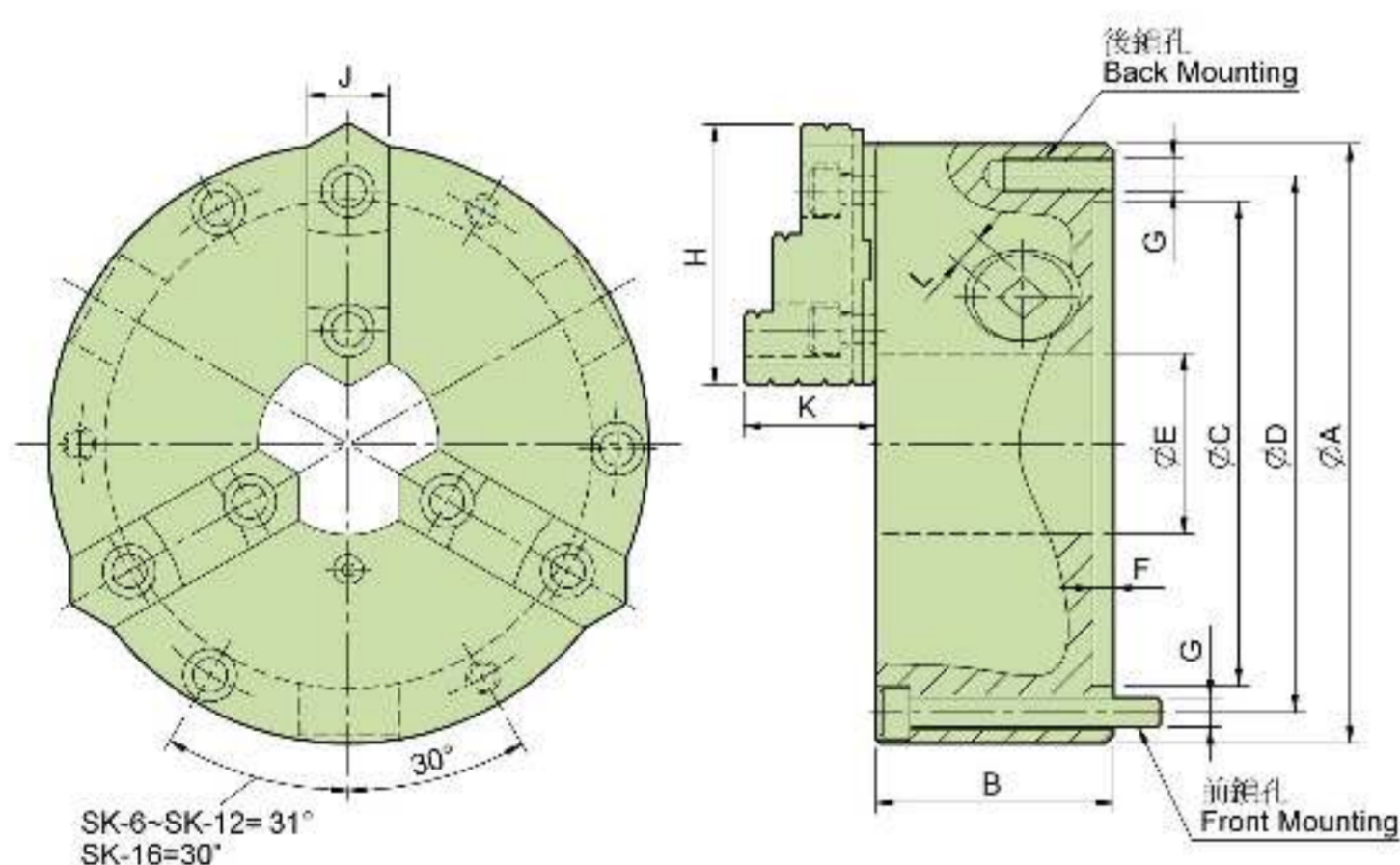

SPECIFICATIONS:

UNIT:mm

Dim Model	A	B	C	D	E	F	G		H	J	K	L	Allowable Handle Torque (kgf·m)	Gripping Force (kgf)	Moment of Inertia I (kg·m ²)	Weight (kg)	Max. Speed (r.p.m.)	Gripping Range	
							Back	Front										O.D. range	I.D. range
SK-6	167	67	130	147	45	5.5	3-M10	3-1/2"φ	72	26	40.2	10	9.0	3300	0.03	9	4000	φ4-φ150	φ55-φ150
SK-7	192	76.5	155	172	58	5.5	3-M10	3-1/2"φ	81.2	28	42	11	11.0	3600	0.06	13.8	3500	φ6-φ150	φ62-φ170
SK-8	200	76.5	180	178	58	5.5	3-M10	3-1/2"φ	82	28	42	11	11.0	3600	0.07	15.5	3200	φ8-φ150	φ68-φ180
SK-9	232	84	190	210	70	6	3-M12	3-1/2"φ	90.9	32	51.2	12	15.0	3900	0.16	22	2900	φ11-φ220	φ70-φ210
SK-10	273	87	230	250	89	8	3-M12	3-1/2"φ	100.5	35	56.7	12	15.5	4800	0.26	29.7	2500	φ12-φ260	φ80-φ250
SK-12	310	96	280	285	105	7	3-M12	3-1/2"φ	114.5	40	56.8	14	21.0	5100	0.58	43.5	2200	φ15-φ300	φ90-φ290
SK-16	405	122	345	375	180	8.7	—	6-1/4"φ	148.6	50	76.1	15	23.0	4500	1.72	98	1500	φ30-φ360	φ110-φ360

SPECIFICATIONS:

UNIT:mm

Dim Model	A	B	C	D	E	F	G		H	J	K	L	Allowable Handle Torque (kgf·m)	Gripping Force (kgf)	Moment of Inertia I (kg·m ²)	Weight (kg)	Max. Speed (r.p.m.)	Gripping Range	
							Back	Front										O.D. range	I.D. range
SIK-7	192	76.5	155	172	58	5.5	3-M10	—	82	28	42	11	11.0	3600	0.06	14.1	3500	φ6-φ180	φ62-φ170
SIK-9	232	84	190	210	70	6	3-M12	—	96	32	51.2	12	15.0	3900	0.16	22.2	2900	φ11-φ220	φ70-φ210
SIK-12	310	96	280	285	105	7	3-M12	—	114.5	40	56.8	14	21.0	5100	0.58	45	2200	φ15-φ300	φ90-φ290
SIK-16	405	122	345	375	180	8.7	—	6-1/4"φ	148.6	50	76.1	15	23.0	4500	1.72	106	1500	φ30-φ360	φ110-φ360



KD SERIES

SPECIFICATIONS:

**3-JAW STRONG SCROLL CHUCKS
D1 CAMLOCK DIRECT MOUNTING,
2-PIECE JAWS**

(ASA spindle nose D1-4, D1-5, D1-6, D1-8)

American standard camlock type with 2-piece reversible hard top jaws.

1. Gripping accuracy of 0.03mm(0.0012inch)T.I.R.
2. Standard accessories A chuck wrench and hex. key. One set of mounting bolts.(UNC-bolts)
3. The body is made of MEEHANITE.It is suitably used for high speed revolution and 3 times more durable than regular chucks.



KA SERIES

SPECIFICATIONS:

**3-JAW STRONG SCROLL CHUCKS
A1 DIRECT MOUNTING, 2-PIECE JAWS**

(ASA spindle nose A1-5, A1-6)

American standard camlock type with 2-piece reversible hard top jaws.

1. Gripping accuracy of 0.03mm(0.0012inch)T.I.R.
2. Standard accessories A chuck wrench and hex. key. One set of mounting bolts.(UNC-bolts)
3. The body is made of MEEHANITE.It is suitably used for high speed revolution and 3 times more durable than regular chucks.

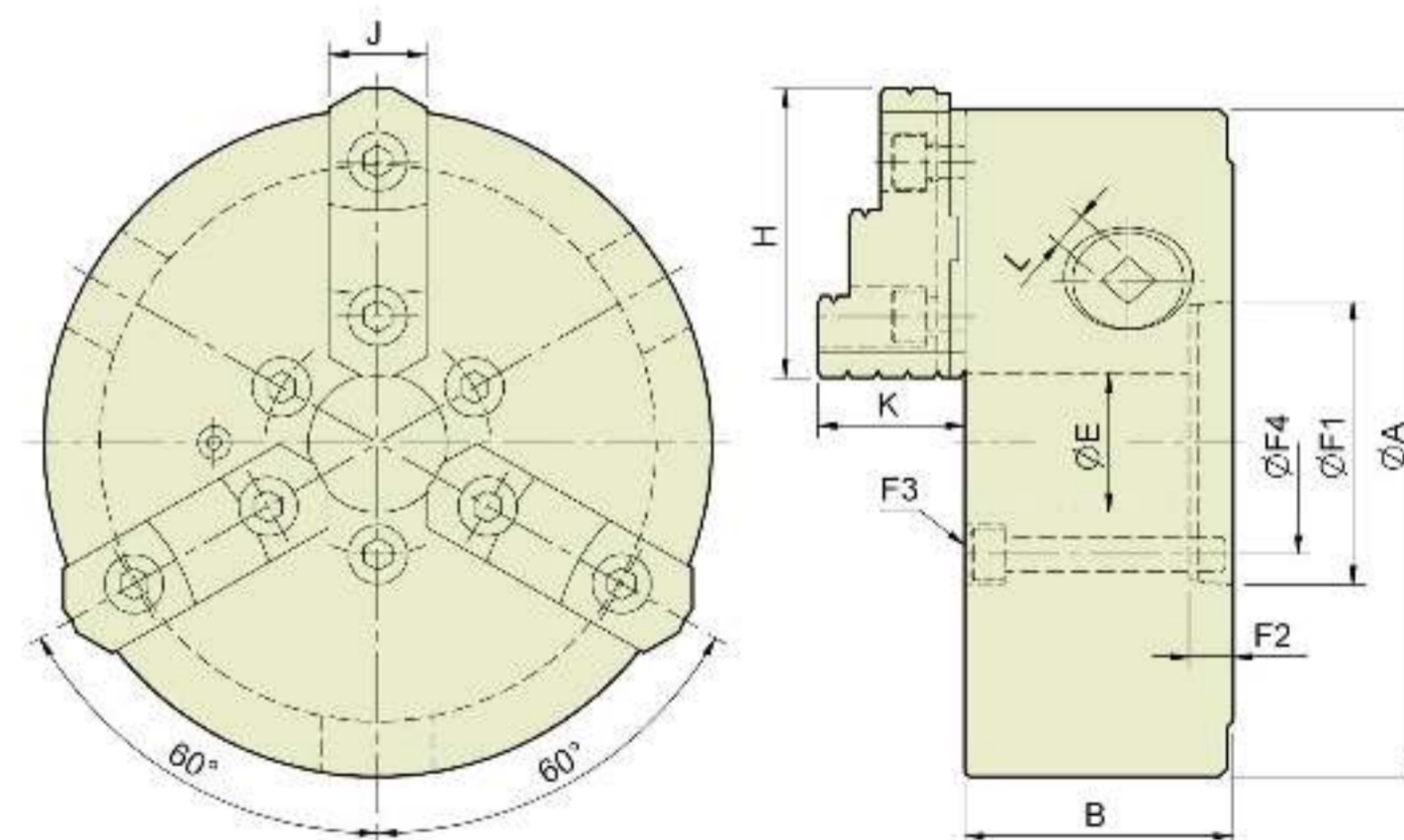
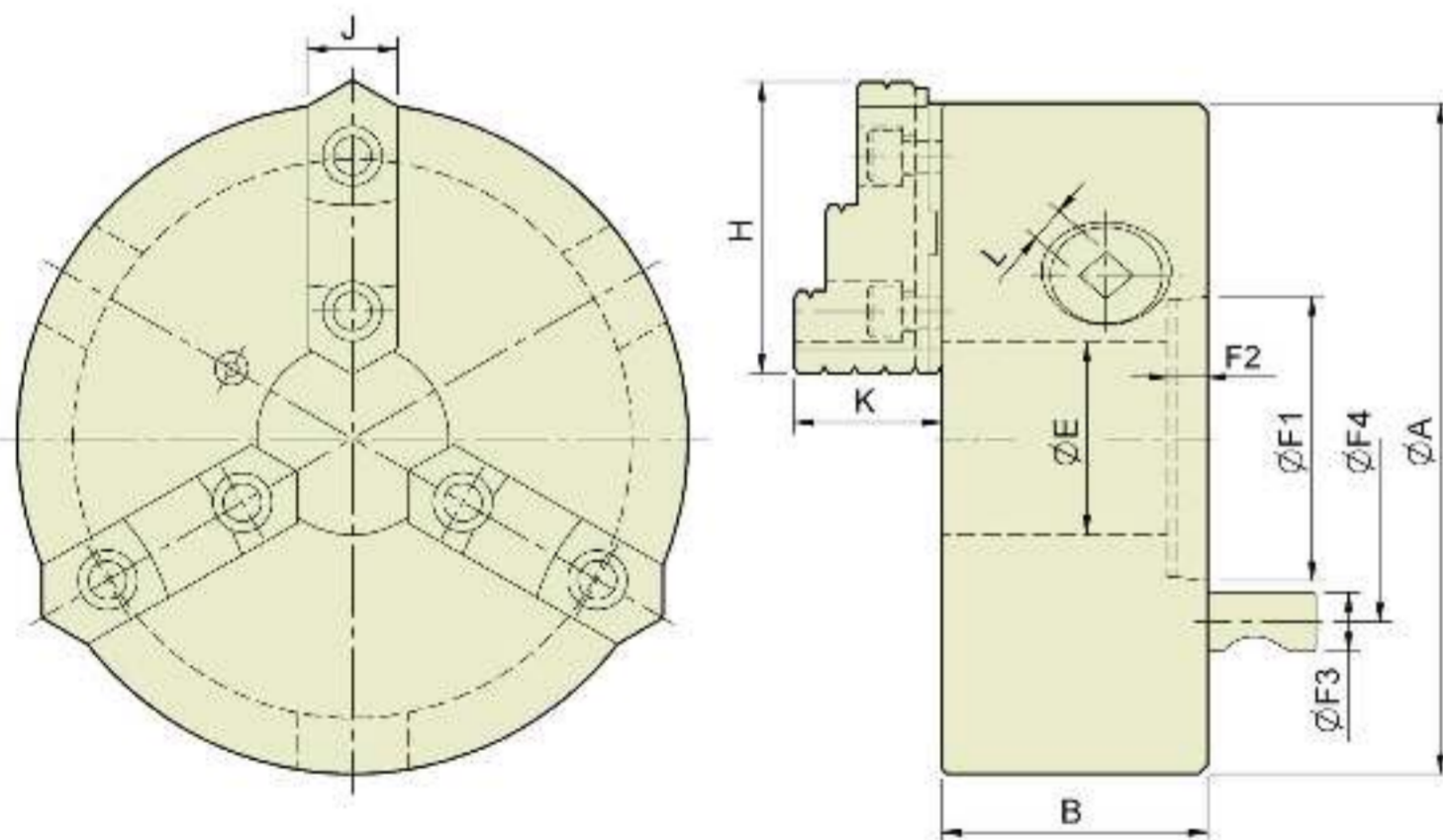

SPECIFICATIONS:

UNIT:mm

Model	Dim Spindle Size	A	B	E	L	H	J	K	Mounting Dimensions				Allowable Handle Torque (kgf·m)	Gripping Force (kgf)	Moment of Inertia I (kg·m ²)	Weight (kg)	Max. Speed (r.p.m.)	Gripping Range	
									F1	F2	F3	F4						O.D. range	I.D. range
KD4-6"	D1-4	166	72	46	10	72	28	39	83.513	13	15.8	82.55	9.0	3300	0.04	11	4000	ø8-ø160	ø55-ø150
KD4-8"	D1-4	200	77.2	53	11	82	28	42.2	83.513	13	15.8	82.55	11.5	3800	0.07	18.5	3200	ø8-ø180	ø62-ø170
KD5-8"	D1-6	200	77.2	56	11	82	28	42.2	82.563	16	19	104.78	11.5	3900	0.07	18	3200	ø8-ø180	ø62-ø170
KD6-8"	D1-6	200	77.2	58	11	82	28	42.2	106.375	17	22.2	133.35	11.5	3900	0.07	17	3200	ø8-ø180	ø62-ø170
KD6-10"	D1-6	250	86	76	12	90.9	32	50.8	106.375	17	22.2	133.35	19.5	4800	0.2	29.5	2500	ø11-ø220	ø70-ø210
KD6-12"	D1-6	306	107.5	108	14	114.5	40	57.8	106.375	18.5	22.2	133.35	21.0	5100	0.5	47	2200	ø15-ø300	ø90-ø290
KD8-10"	D1-8	250	86	80	12	90.9	32	50.8	139.719	19	25.4	171.45	19.5	4900	0.2	27	2500	ø11-ø220	ø70-ø210
KD8-12"	D1-8	306	107.5	103	14	114.5	40	57.8	139.719	18	25.4	171.45	21.0	5100	0.5	47	2200	ø15-ø300	ø90-ø290

SPECIFICATIONS:

UNIT:mm

Model	Dim Spindle Size	A	B	E	L	H	J	K	Mounting Dimensions				Allowable Handle Torque (kgf·m)	Gripping Force (kgf)	Moment of Inertia I (kg·m ²)	Weight (kg)	Max. Speed (r.p.m.)	Gripping Range	
									F1	F2	F3	F4						O.D. range	I.D. range
KA5-8"	A1-5	200	77.2	40	11	81.2	28	42.2	82.563	4.288	3-M12	61.9	11.0	3800	0.07	18	3200	ø8-ø180	ø62-ø170
KA6-8"	A1-6	200	77.2	53	11	81.2	28	42.2	106.375	5.875	3-M12	82.5	11.0	3800	0.07	18	3200	ø8-ø180	ø62-ø170
KA6-10"	A1-6	250	86	53	12	90.9	32	50.8	106.375	5.875	3-M12	82.5	18.0	4800	0.2	29.5	2500	ø11-ø220	ø70-ø210
KA6-12"	A1-6	306	107.5	53	14	114.5	40	57.8	106.375	5.875	3-M12	82.5	21.0	5100	0.5	47	2200	ø15-ø300	ø90-ø290
KA8-12"	A1-8	306	107.5	77	14	114.5	40	57.8	139.719	17.46	5-M16	111.1	21.0	5100	0.5	47	2200	ø15-ø300	ø90-ø290



SE SERIES
SPECIFICATIONS:
6-JAW SCROLL CHUCK PLAIN BANK

1. SE types are specially suit for drilling*endmilling*tapping or grinding in tool grinders.
2. Huge bore diameter design for wider application of bar workpieces.
3. SE type feature gripping for thin tube and high roundness accuracy.
4. The body is made of MEEHANITE. It is suitably used for high speed revolution and 3 times more durable than regular chucks.



SKC SERIES
SPECIFICATIONS:
SOFT JAWS FOR STRONG SCROLL CHUCKS

1. Soft jaws for strong scroll chuck.
2. Manufactured in special specification.

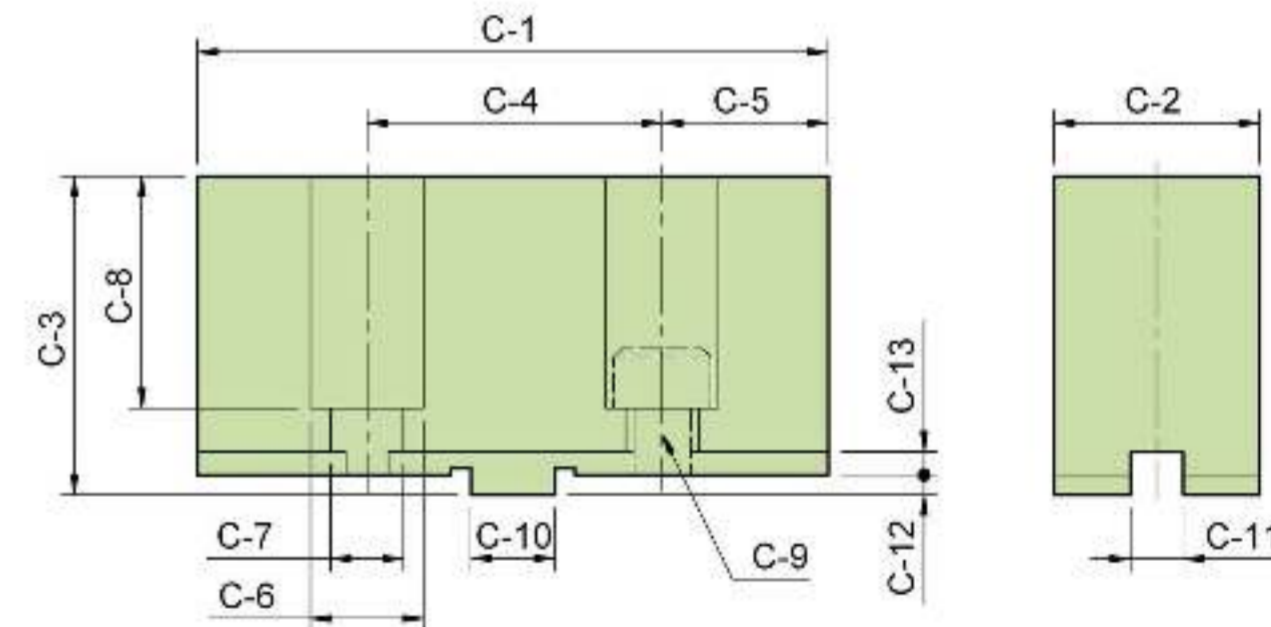
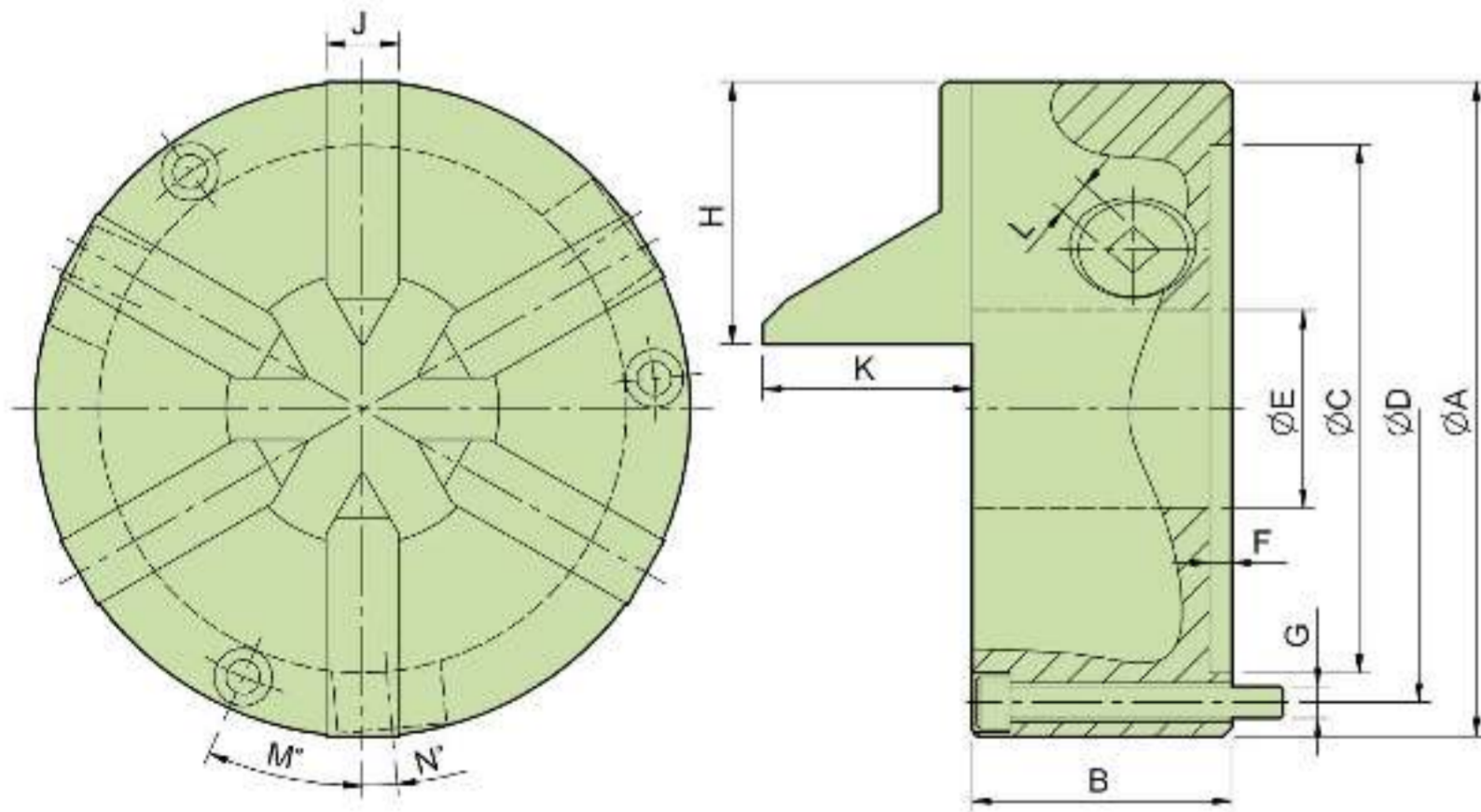

SPECIFICATIONS:

UNIT:mm

Model	A	B	C	D	E	F	G	H	J	K	L	M	N	Weight (kg)	Max. Speed (r.p.m.)	Gripping O.D. Range
SE-4	112	66	80	95	32	4.8	3-M8	45	14	39.7	8	30	6.5	4	2500	φ2-φ32
SE-6	165	67	130	147	51	5.5	3-M8	66.5	19	40.7	10	23.3	6.2	9	2000	φ3-φ51
SE-7	192	76.5	155	172	80	5.5	3-M10	77	21.5	61.5	11	24	5.3	14	2000	φ3-φ81

SPECIFICATIONS:

UNIT:mm

Model	C-1	C-2	C-3	C-4	C-5	C-6	C-7	C-8	C-9	C-10	C-11	C-12	C-13	Matching Chuck	3 Jaw Weight (kg)
SKC06	73	26	37	36	17.5	14	8.5	27	M8	12.68	7.94	3	3.5	SK-6, KD-6"	1.5
SKC07	95	31	48	44.5	25.25	17	11	35	M10	12.68	7.94	3	3.5	SK-7, SK-8, KD-8", KA-8"	2.7
SKC09	110	37	48	54	28	19	13	34	M12	19.03	12.7	3	3.5	SK-9, SK-10, KD-10", KA-10"	3.7
SKC12	125	40	54	63.5	30.75	19	13	40.5	M12	19.03	12.7	3	3.5	SK-12, KD-12", KA-12"	4.9
SKC16	160	50	70	76.2	41.9	25	17	48	M16	19.03	12.7	6	3.5	SK-16	11



N-200 SERIES
SPECIFICATIONS:
3-JAW WEDGE TYPE THROUGH-HOLE POWER CHUCK (WITHOUT ADAPTOR)

- 1. More large bore
- 2. Highest revolution

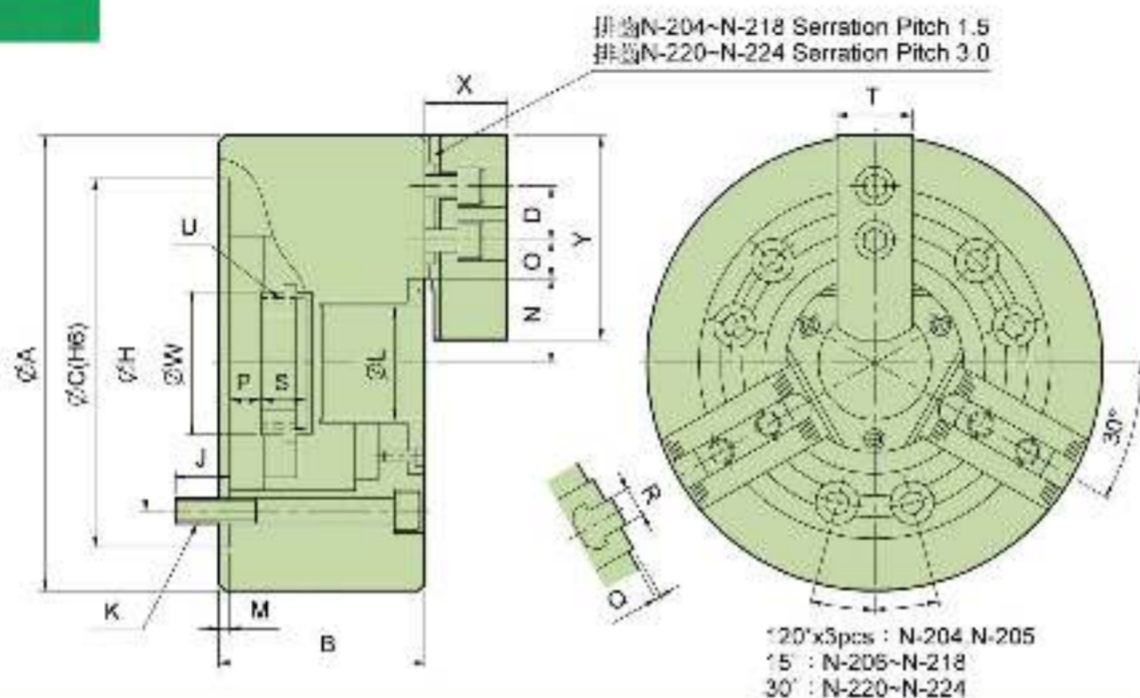

SPECIFICATIONS:

Model	Through-Hole (mm)	Plunger Stroke (mm)	Jaw Stroke (mm)	Max. Draw Bar Pull Force (kgf)	Max. Gripping Force (kgf)	Max. Operating Pressure (kgf/cm ²)	Max. Speed (r.p.m.)	Weight (kg)	Moment of Inertia I (kg·m ²)	Matching Cylinder	Matching Soft Jaw	Matching Hard Jaw	Gripping O.D. Range (mm)
N-204	∅26	10	5.4	1428	2906	31.6	8000	4	0.007	M0928	HC04	HJ05	∅4~∅110
N-205	∅33	10	5.4	1784	3671	28.5	7000	7	0.018	M1036	HC05	HJ05	∅6~∅135
N-206	∅45	12	5.5	2243	5812	28.5	6000	13.5	0.057	M1246	HC06	HJ06	∅15~∅169
N-208	∅52	16	7.4	3558	9075	26.5	5000	23	0.17	M1552	HC08	HJ08	∅20~∅210
N-210	∅75	19	8.8	4385	11319	27.5	4200	35	0.315	M1875	HC10	HJ10	∅25~∅254
N-212	∅91	23	10.6	5812	14990	27.5	3300	56.5	0.737	M2091	HC12	HJ12	∅30~∅304
N-215	∅117.5	23	10.6	7240	18355	23.5	2500	111	2.27	M2511	HC15	HJ15	∅50~∅381
N-218	∅117.5	23	10.6	7240	18355	23.5	2000	164	4.45	M2511	HC15	HJ15	∅50~∅450
N-220	∅180	23	10.6	9177	23861	30.5	1800	190	6.5	ML2816	HC24-1	HJ24-1	∅120~∅510
N-224	∅205	26	12	9177	23861	30.5	1400	270	14.8	ML3320	HC24-1	HJ24-1	∅150~∅610

DIMENSIONS:

Model	A	B	C (H6)	D	H	J	K	L	M	N max.	O max.	O min.	P max.	P min.	Q	R	S	T	U max.	W	X	Y
N-204	110	59	85	14	70.6	18	3-M10x60	26	4	23.2	13.75	6.75	3.5	-6.5	2	10	17.5	23	M32x1.5	38	24	49.5
N-205	135	60	110	14	82.55	15	3-M10x80	33	4	26.5	19.75	7.75	1	-9	2	10	20	25	M40x1.5	45	31	54
N-206	169	81	140	20	104.78	16	6-M10x80	45	5	32	22.75	9.25	11	-1	2	12	19	31	M55x2	60	37	73
N-208	210	91	170	25	133.35	20	6-M12x90	52	5	38.7	29.75	14.75	14.5	-1.5	2	14	20.5	35	M60x2	66	38	95
N-210	254	100	220	30	171.45	22	6-M16x100	75	5	51	33.75	14.25	8.5	-10.5	2	16	25	40	M85x2	94	43	110
N-212	304	110	220	30	171.45	23	6-M18x110	91	6	61.3	45.75	15.75	8	-15	2	21	28	50	M100x2	108	51	130
N-215	381	133	300	43	235	35	6-M20x135	117.5	6	82	45.25	16.75	7	-16	5	22	43	62	M130x2	139	66	165
N-218	450	133	300	43	235	35	6-M20x135	117.5	6	82	79.75	16.75	7	-16	5	22	43	62	M130x2	139	66	165
N-220	510	134	380	60	330.2	35	6-M24x135	180	6	112.5	69	23	11	-12	5	25	38	65	M190x2	206	73	180
N-224	610	147	520	60	463.6	35	6-M24x150	205	6	139.9	87.5	24.5	16	-10	5	25	38	65	M215x3	230	73	180

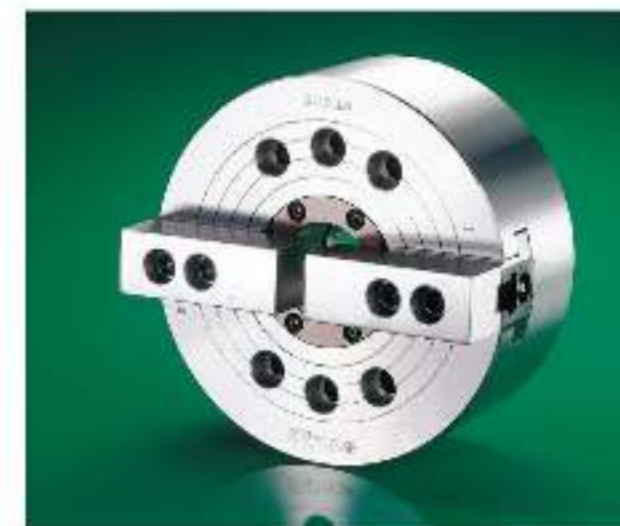

NT-200 SERIES
SPECIFICATIONS:
2-JAW WEDGE TYPE THROUGH-HOLE POWER CHUCK (WITHOUT ADAPTOR)

- 1. All sliding surfaces are hardened and ground for accurate actual running and long service repeatability. Lubrication nipple in each base jaw.
- 2. Base jaw: 1.5mmx60° serrition.
- 3. Mounting: Adaptor mounting to fit with DIN, ISO, BS, ASA B5.9 type A spindles.

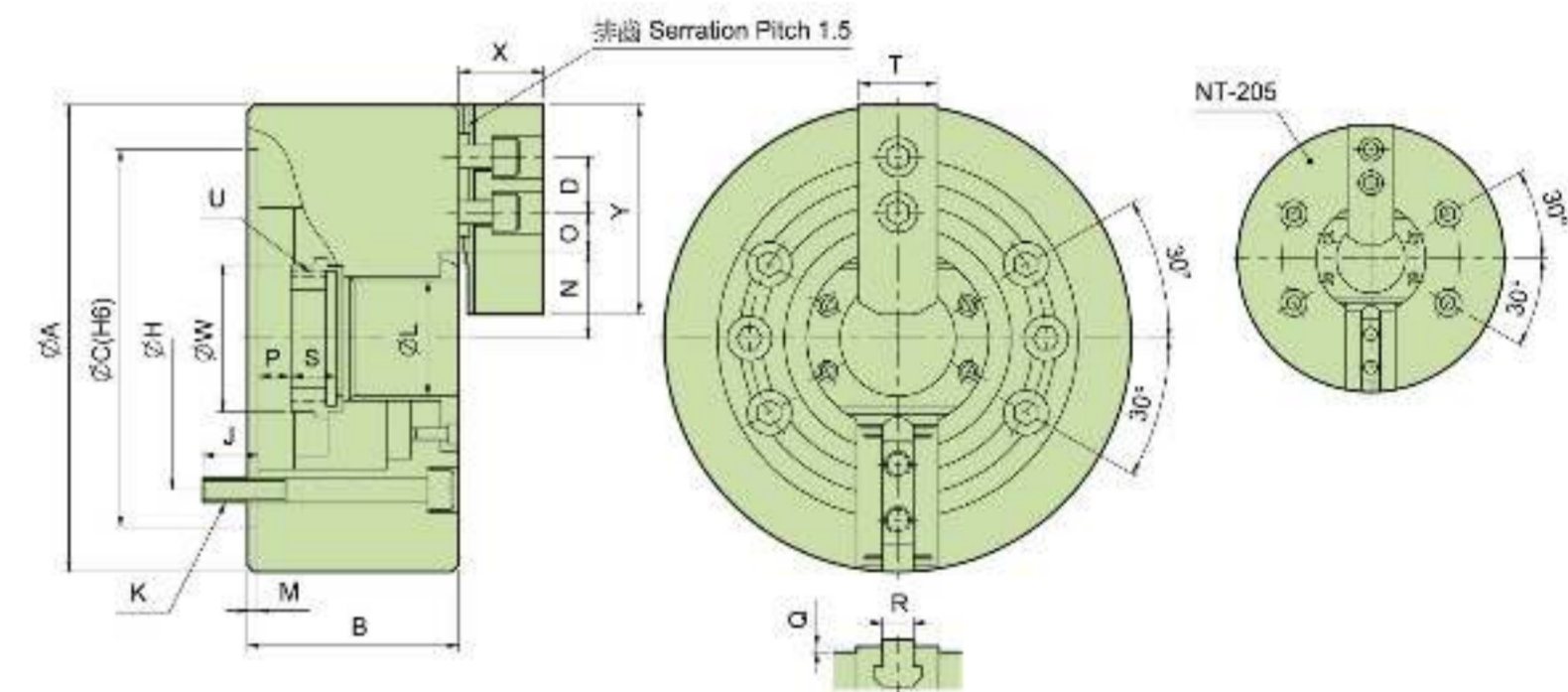

SPECIFICATIONS:

Model	Through-Hole (mm)	Plunger Stroke (mm)	Jaw Stroke (mm)	Max. Draw Bar Pull Force (kgf)	Max. Gripping Force (kgf)	Max. Operating Pressure (kgf/cm ²)	Max. Speed (r.p.m.)	Weight (kg)	Moment of Inertia I (kg·m ²)	Matching Cylinder	Matching Hard Jaw	Matching Soft Jaw	Gripping O.D. Range (mm)
NT-205	∅33	10	5.4	1189	2447	19.5	7000	6.8	0.017	M1036	HJ05	HC05	∅6~∅135
NT-206	∅45	12	5.5	1495	3875	18.9	6000	12.8	0.054	M1246	HJ06	HC06	∅15~∅169
NT-208	∅52	16	7.4	2366	5975	18.4	5000	22	0.163	M1552	HJ08	HC08	∅20~∅210
NT-210	∅75	19	8.8	2927	7546	18.4	4200	34	0.306	M1875	HJ10	HC10	∅25~∅254
NT-212	∅91	23	10.6	3875	9789	18.4	3300	55	0.717	M2091	HJ12	HC12	∅30~∅304
NT-215	∅117.5	23	10.6	4823	12236	15.3	2500	106	2.17	M2511	HJ15	HC15	∅50~∅381

DIMENSIONS:

Model	A	B	C (H6)	D	H	J	K	L	M	N max.	O max.	O min.	P max.	P min.	Q	R	S	T	U max.	W	X	Y
NT-205	135	80	110	14	82.55	15	4-M10x80	33	4	26.5	19.75	7.75	1	-9	2	10	20	23	M40x1.5	45	31	54
NT-206	169	81	140	20	104.78	16	6-M10x80	45	5	32	22.75	9.25	11	-1	2	12	19	31	M55x2	60	37	73
NT-208	210	91	170	25	133.35	20	6-M12x90	52	5	38.7	29.75	14.75	14.5	-1.5	2	14	20.5	35	M60x2	66	38	95
NT-210	254	100	220	30	171.45	22	6-M16x100	75	5	51	33.75	14.25	8.5	-10.5	2	16	25	40	M85x2	94	43	110
NT-212	304	110	220	30	171.45	23	6-M18x110	91	6	61.3	45.75	15.75	8	-15	2	21	28	50	M100x2	108	51	130
NT-215	381	133	300	43	235	35	6-M20x135	117.5	6	82	45.25	16.75	7	-16	5	22	43	62	M130x2	139	66	165



NIT-200 SERIES

SPECIFICATIONS:

4-JAW WEDGE TYPE THROUGH HOLE POWER CHUCK (WITHOUT ADAPTOR)

- 1.All sliding surfaces are hardened and ground for accurate actual running and long service repeatability. Lubrication nipple in each master jaw.
- 2.Master jaw:1.5mmx60° serrition.
- 3.Mounting:Adaptor mounting to fit with DIN, ISO, BS, ASA B5.9 type A spindles.

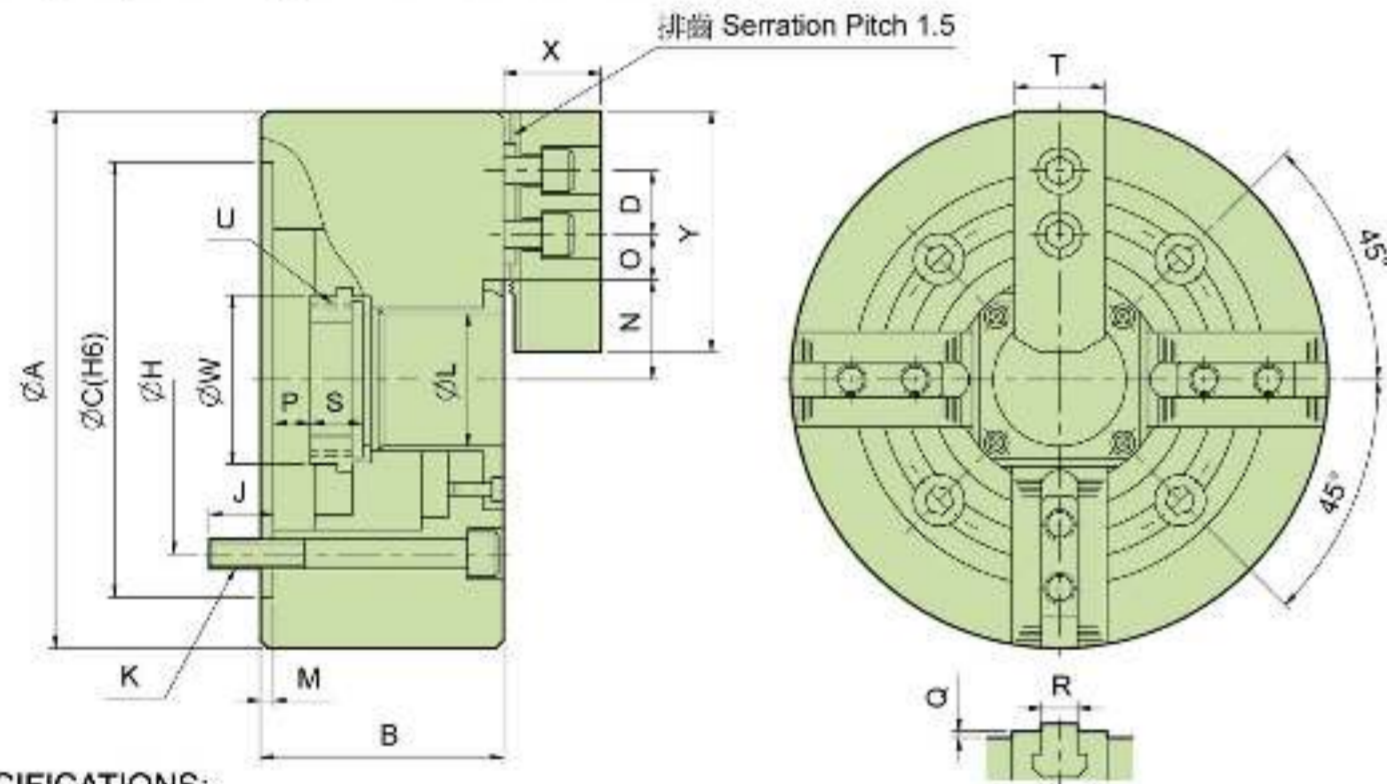

SPECIFICATIONS:

Model Dim	Through-Hole (mm)	Plunger Stroke (mm)	Jaw Stroke (In dia) (mm)	Max. Draw Bar Pull Force (kgf)	Max. Gripping Force (kgf)	Max. Operating Pressure (kgf/cm ²)	Max. Speed (r.p.m.)	Weight (kg)	Moment of Inertia I(kg·m ²)	Matching Cylinder	Matching Hard Jaw	Matching Soft Jaw	Gripping O.D. Range (mm)
NIT-206	45	12	5.5	2243	5812	28.5	4500	13.7	0.051	M1246	HJ06	HC06	φ15~φ169
NIT-208	52	16	7.4	3558	9075	26.5	3600	24	0.177	M1552	HJ08	HC08	φ20~φ210
NIT-210	75	19	8.8	4385	11319	27.5	3200	36	0.324	M1875	HJ10	HC10	φ25~φ254
NIT-212	91	23	10.6	5812	14990	27.5	2700	58.5	0.763	M2091	HJ12	HC12	φ30~φ304
NIT-215	117.5	23	10.6	7240	18355	23.5	1900	114	2.331	M2511	HJ15	HC15	φ60~φ381
NIT-218	117.5	23	10.6	7240	18355	23.5	1500	122	3.2	M2511	HJ15	HC15	φ60~φ450
NIT-224	205	26	12	9177	23661	30.5	1000	264	14.5	M3320	HJ24-1	HC24-1	φ150~φ610

DIMENSIONS:

Model Dim	A	B	C (H6)	D	H	J	K	L	M	N max	O max	O min	P max	P min	Q	R	S	T	U max	V	W	X	Y
NIT-206	169	81	140	20	104.78	16	4-M10x80	45	5	32	22.75	9.25	11	-1	2	12	19	31	M55x2	60	37	73	
NIT-208	210	91	170	25	133.35	20	4-M12x90	52	5	38.7	29.75	14.75	14.5	-1.5	2	14	20.5	35	M60x2	66	38	95	
NIT-210	254	100	220	30	171.46	22	4-M16x100	75	6	51	33.75	14.25	8.5	-10.5	2	18	25	40	M85x2	94	43	110	
NIT-212	304	110	220	30	171.46	23	4-M16x110	91	6	61.3	45.75	15.75	8	-15	2	21	28	50	M100x2	108	51	130	
NIT-215	381	133	300	43	235	35	4-M20x135	117.5	8	82	46.25	16.75	7	-18	5	22	43	62	M130x2	139	66	165	
NIT-218	450	133	300	43	235	35	4-M20x135	117.5	8	82	79.75	16.75	7	-16	5	22	43	62	M130x2	139	66	165	
NIT-224	610	147	520	60	463.6	35	8-M24x150	205	8	139.9	87.5	24.5	16	-10	5	25	38	65	M215x3	230	73	180	



NHT SERIES

SPECIFICATIONS:

2 JAWS AND 3 JAWS THROUGH HOLE POWER CHUCKS (WITH ADAPTOR)

- 1.Gripping of round or irregular workpiece does not need to change the chuck.
- 2.The chucks are designed according to ASA B5.9 type A spindle.
- 3.The chucks are made from high grade alloy steel. All siding surfaces are hardened and ground for increased running accuracy and longer service life.

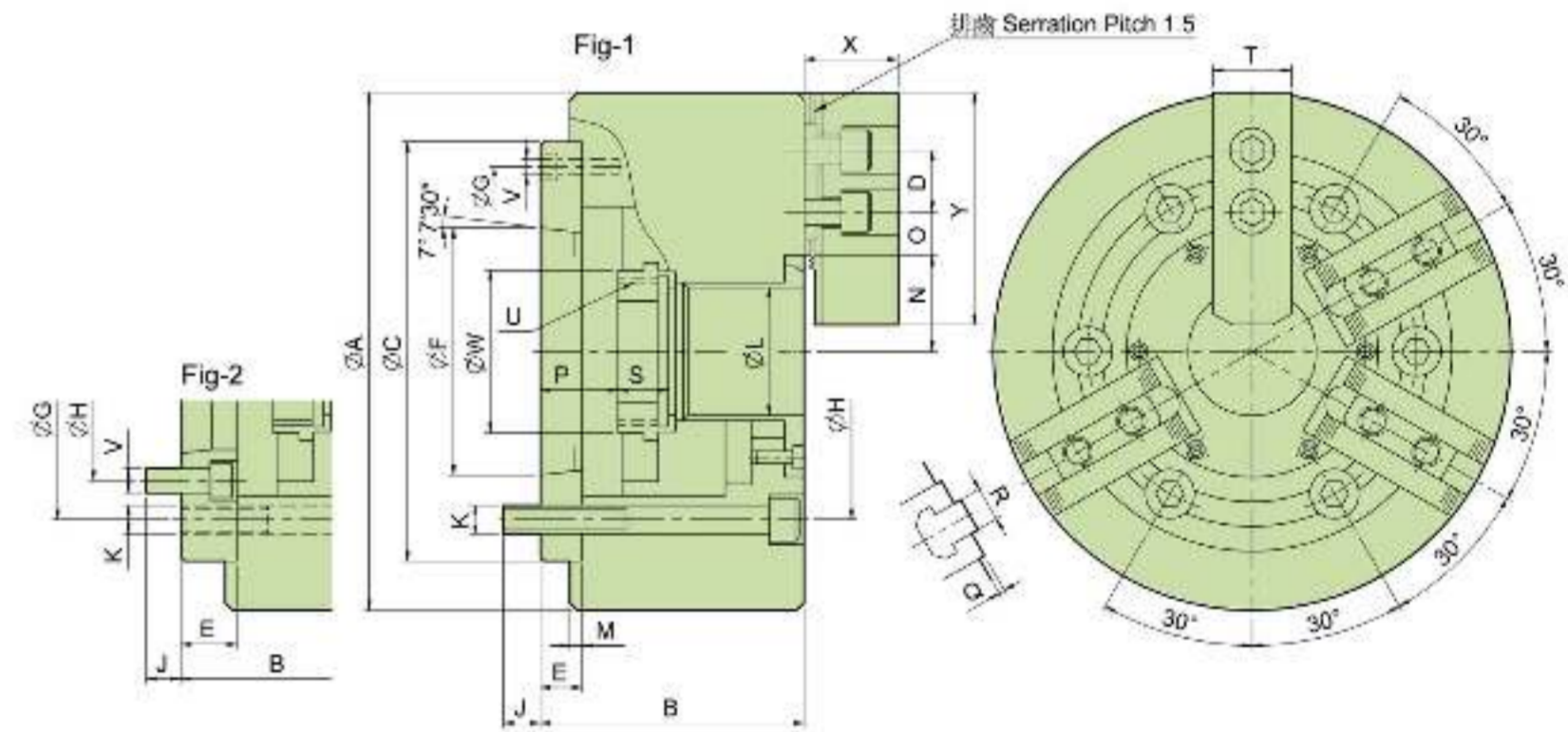

SPECIFICATIONS:

Model Dim	Through-Hole (mm)	Plunger Stroke (mm)	Jaw Stroke (In dia) (mm)	Max. Draw Bar Pull Force (kgf)	Max. Gripping Force (kgf)	Max. Operating Pressure (kgf/cm ²)	Max. Speed (r.p.m.)	Weight (kg)	Matching Cylinder	Matching Soft Jaw	Matching Hard Jaw			
NHT208A5	52	16	7.4	2243	1495	5812	3875	17.2	12.1	3500	25.5	M1552	HC06	HJ06
NHT208A6	52	16	7.4	2243	1495	5812	3875	17.2	12.1	3500	24.7	M1552	HC06	HJ06

DIMENSIONS:

Model Dim	A	B	C	D	E	F	G	H	J	K	L	M	N max	O max	O min	P max	P min	Q	R	S	T	U max	V	W	X	Y	Reference
NHT-208A5	210	113	170	20	23	82.563	133.5	104.78	13	6xM12	52	5	41.8	34	7.5	37.5	21.5	2	12	20.5	32	M60xP2.0	6xM10	66	37	73	Fig-2
NHT-208A6	210	107	170	20	17	108.375	150	133.35	17	6xM12	52	5	41.8	34	7.5	31.5	15.5	2	12	20.5	32	M60xP2.0	3xM6	66	37	73	Fig-1



NB-200A SERIES

SPECIFICATIONS:

3-JAW WEDGE TYPE EXTRA LARGE THROUGH-HOLE POWER CHUCK (WITH ADAPTOR)

1. More large bore: Having the largest bore in wedge type power operated chucks.
2. 20% large bore: Approximately 20% higher speed, higher gripping force and larger bore compared with usual chucks.
3. Model N-200A chucks are assembled with adaptor for ASA B5.9 type A spindles.
4. Model N-200A chucks are manufactured from high grade alloy steel, All sliding surfaces are hardened and ground for accurate actual running and long service repeatability.

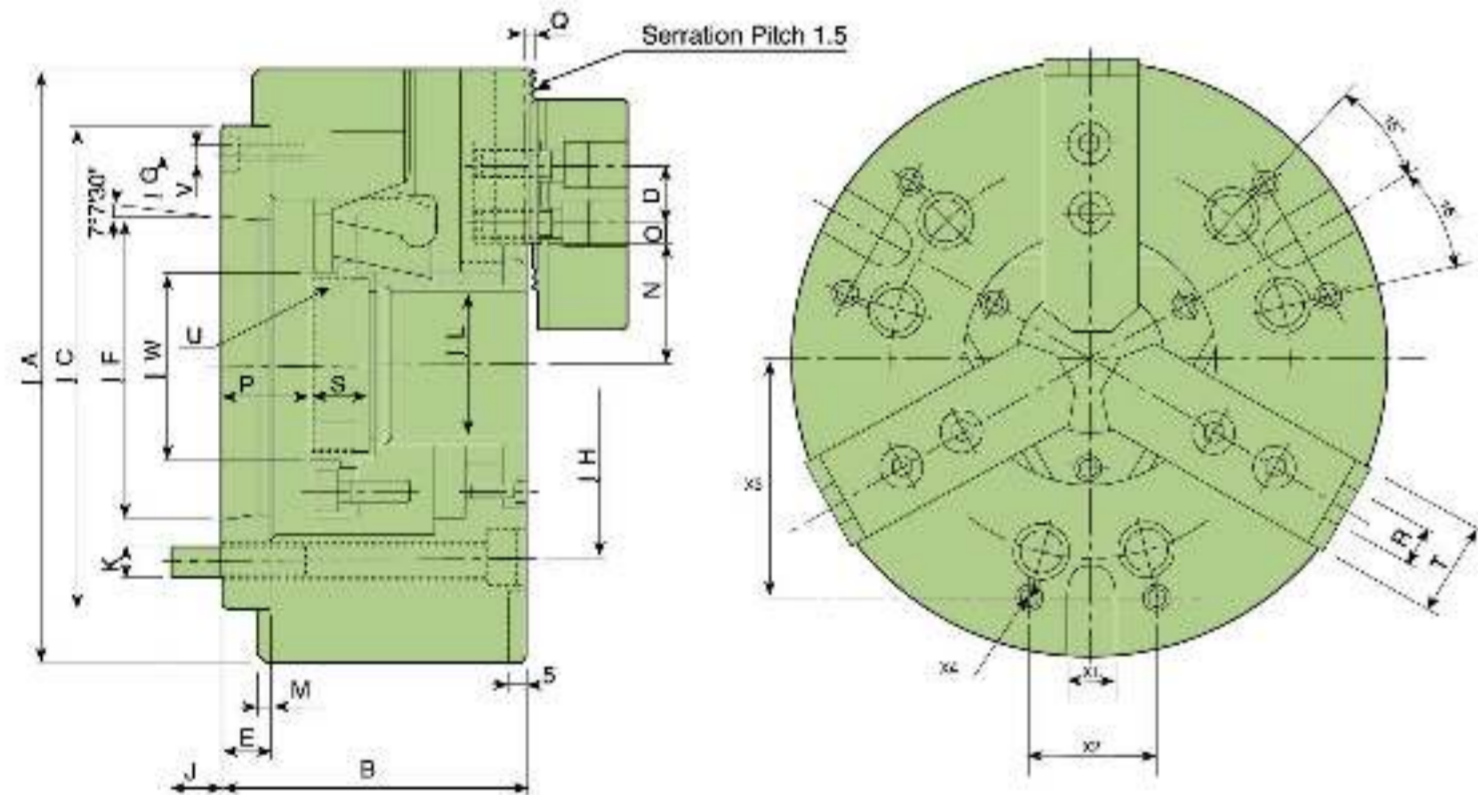

SPECIFICATIONS:

Model	Through-Hole (mm)	Plunger Stroke (mm)	Jaw Stroke (mm)	Max. Draw Bar Pull Force (kgf)	Max. Gripping Force (kgf)	Max. Operating Pressure (kgf/cm ²)	Max. Speed (r.p.m.)	Weight (kg)	Moment of Inertia I (kg·m ²)	Matching Cylinder	Matching Soft Jaw	Matching Hard Jaw
NB-306A5	∅62	12	5.4	2200	5700	18.4	6000	14	0.06	M1552	HC06	HJ06
NB-208A6	∅66	16	7.4	3500	8973	20.5	4600	24	0.14	M1868	HC08	HJ08
NB-210A8	∅78	19	8.8	4300	11000	27.5	4200	37.4	0.4	M1878	HC10	HJ10
NB-212A11	∅122	23	10.6	5800	15000	20.5	3200	65	0.95	M2511	HC12	HJ12

DIMENSIONS:

Model	A	B	C (H6)	D	E	F	G	H	J	K	L	M	N min	N max	O min	P max	P min	Q	R	S	T	U max	V	W	X1 (H12)	X2	X3	X4
NB-306A5	170	81	140	20	15	82.563	118	104.78	14.5	6xM10	52	5	34.3	18.25	9.25	26	14	2	12	20	32	M60x2.0	3xM6	65	16	36	65	M8
NB-208A6	210	103	170	25	17	106.375	150	133.35	19.5	6xM12	66	5	42	23.75	11.75	31.5	15.5	2	14	20	37	M74x2.0	3xM6	80	16	45	80	M8
NB-210A8	254	113	220	30	18	139.719	190	171.45	24	6xM16	78	5	53	33.75	14.25	26.5	7.5	2	16	25	42	M87x2.0	6xM8	94	16	60	102	M10
NB-212A11	315	134	300	30	22	196.869	260	235	28	6xM20	122	6	74.2	36.25	12.75	42	19	2	21	28	52	M135x2.0	3xM10	143	20	60	138	M10

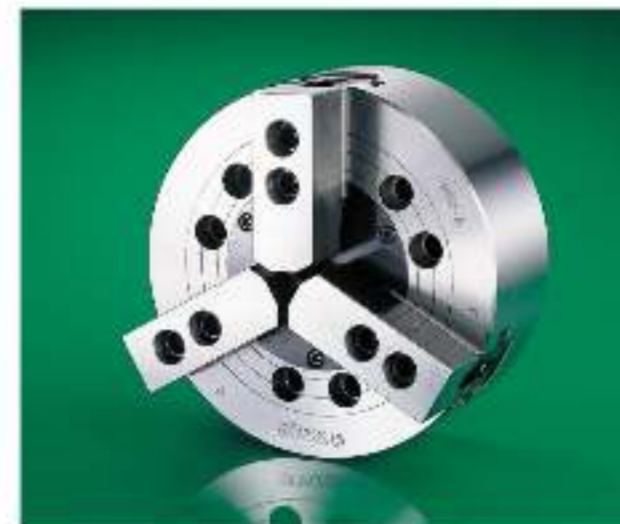

V SERIES

SPECIFICATIONS:

3-JAW WEDGE TYPE NON THROUGH HOLE POWER CHUCK (WITHOUT ADAPTOR)

1. High performance: Similar high performance to N series.
2. Chuck mounting screws: Metric or UNC socket head cap screws are supplied for bolting the chuck to the spindle.
3. Alternative spindle adaptors: ASA or DIN adaptors can be supplied to fit machine spindle.

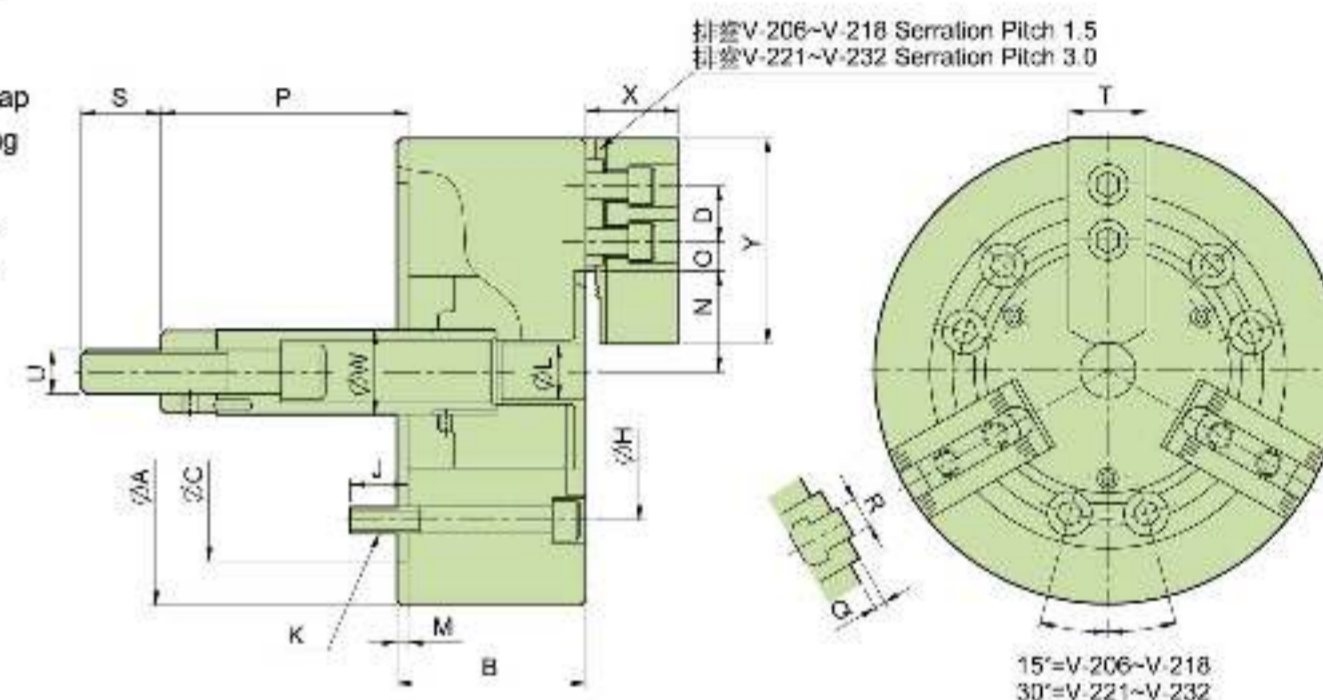

SPECIFICATIONS:

Model	Jaw Stroke (In dia) (mm)	Plunger Stroke (mm)	Max. Pull Force (kgf)	Max. Gripping Force (kgf)	Max. Operating Pressure (kgf/cm ²)	Max. Speed (r.p.m.)	Weight (kg)	Moment of Inertia I (kg·m ²)	Matching Cylinder	Matching Hard Jaw	Matching Soft Jaw	Gripping O.D. Range (mm)
V-206	9.2	20	1835	5353	26.5	5200	12	0.045	MS105C	HJ06	HC06	∅18~∅165
V-208	9.7	21	2549	7648	25.5	4500	23	0.137	MS125C	HJ08	HC08	∅26~∅210
V-210	8.8	25	2957	11013	28.6	4000	34.5	0.3	MS125C	HJ10	HC10	∅26~∅254
V-212	10.5	30	4181	15907	27.5	3300	59.5	0.725	MS150C	HJ12-1	HC12-1	∅26~∅304
V-215	16	35	8362	25391	32.6	3000	101	1.8	MS200C	HJ15-1	HC15-1	∅68~∅381
V-218	16	35	8362	25391	32.6	2700	116	2.9	MS200C	HJ15-1	HC15-1	∅130~∅450
V-221	16	35	8362	27838	32.6	1940	181	6.2	MS200C	HJ24-1	HC24-1	∅65~∅530
V-224	16	35	8362	27838	32.6	1760	216	7	MS200C	HJ24-1	HC24-1	∅152~∅610
V-232	18.6	35	8362	27838	32.6	600	365	27.3	MS200C	HJ24-1	HC32-1	∅100~∅810

DIMENSIONS:

Model	A	B	C	D	H	J	K	L	M	N max	O max	O min	P max	P min	Q	R	S	T	U	W	X	Y
V-206	165	74	140	20	104.78	14	6-M10x70	21	5	38.7	15.25	9.25	104.6	84.6	4	12	36	31	M16x2.0	34	39	73
V-208	210	85	170	25	133.35	20	6-M12x85	25	5	46.85	22.25	11.75	132	111	5	14	36	35	M20x2.5	38	41	95
V-210	254	89	220	30	171.45	23	6-M16x85	34	5	51.1	30.75	11.25	158	133	5	16	36	40	M20x2.5	45	46	110
V-212	304	106	220	30	171.45	23	6-M16x105	34	6	61	48.75	12.75	163	133	5	18	36	50	M20x2.5	50	54	130
V-215	381	114	300	43	235	29	6-M20x115	—	6	77.5	50.25	23.25	104	89	2	25.5	55	50	M30x3.5	60	63	165
V-218	450	114	300	43	235	29	6-M20x115	—	6	108	50.25	23.25	92	57	2	25.5	55	50	M30x3.5	60	63	165
V-221	530	125	380	60	330.2	31	6-M24x115	—	6	86	93.5	24.5	97	82	7.5	25	55	65	M30x3.5	60	76	180
V-224	610	125	380	60	330.2	31	6-M24x115	—	6	125	93.5	24.5	97	82	7.5	25	55	65	M30x3.5	60	76	180
V-232	810	135	380	80	330.2	26	6-M24x115	—	6	104.9	196.5	25.5	74	39	9	25	60	74	M30x3.5	60	97	210



VT&VIT SERIES

SPECIFICATIONS:

2-JAW AND 4-JAW WEDGE TYPE NON THROUGH HOLE POWER CHUCK (WITHOUT ADAPTOR)

1. Suitable for special applications:
Used to hold special shape work pieces such as square bar or flanges which is not possible with 3 jaw chucks.
2. Interchangeable with V or VA series.
3. Basic dimensions are the same as V type.
4. High performance as V type.

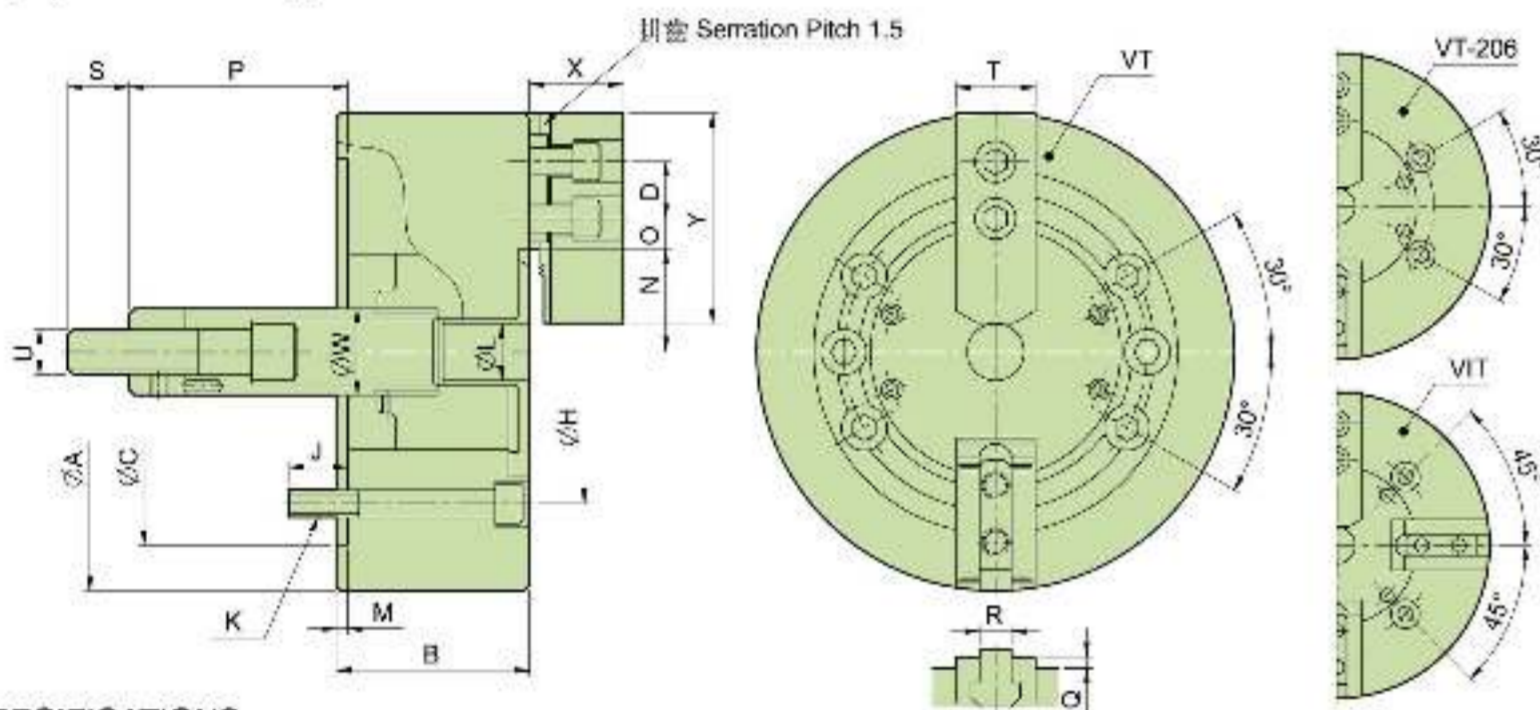

SPECIFICATIONS:

Model Dim	Plunger Stroke (mm)	Jaw Stroke (in dia) (mm)	Max. Pull Force (kgf)	Max. Gripping Force (kgf)	Max. Operating Pressure (kgf/cm ²)	Max. Speed (r.p.m.)	Weight (kg)	Moment of Inertia I (kg·m ²)	Matching Cylinder	Matching Hard Jaw	Matching Soft Jaw	Gripping O.D Range (mm)
VT-206	20	9.2	1224	3569	17.3	5200	12	0.045	MS103C MF1100	HJ06	HC06	φ18~φ165
VT-208	21	9.7	1683	5096	16.3	4500	22	0.13	MS120C MF125	HJ08	HC08	φ28~φ210
VT-210	25	8.8	1988	7342	19.4	4000	33.5	0.29	MS125C MF125	HJ10	HC10	φ24~φ254
VT-212	30	10.5	2804	10605	18.4	3300	58	0.7	MS150C MF150	HJ12-1	HC12-1	φ18~φ304
VIT-212	30	10.5	4181	15907	27.5	2800	64	0.78	MS150C MF150	HJ12-1	HC12-1	φ18~φ304
VT-215	35	16	5557	16927	21.7	3000	100.6	1.7	MS200C	HJ15-1	HC15-1	φ68~φ381
VIT-218	35	16	8362	25391	32.6	2300	119	2.975	MS200C	HJ15-1	HC15-1	φ130~φ450
VIT-224	35	16	8362	27838	32.6	1520	228	7.3	MS200C	HJ24-1	HC24-1	φ152~φ610
VIT-232	35	18.7	8362	21924	32.6	920	400	30	MS200C	HJ24-1	HC32-1	φ100~φ810

DIMENSIONS:

Model Dim	A	B	C	D	H	J	K	L	M	N max.	O max.	O min.	P max.	P min.	Q	R	S	T	U	W	X	Y
VT-206	165	74	140	20	104.78	14	4-M10x70	21	5	38.7	15.25	9.25	104.6	84.6	4	12	36	31	M16x2.0	34	39	73
VT-208	210	85	170	25	133.35	20	6-M12x85	25	5	46.85	22.25	11.75	132	111	5	14	36	35	M20x2.5	38	41	95
VT-210	254	89	220	30	171.45	23	6-M16x85	34	5	51.1	30.75	11.25	158	133	5	16	36	40	M20x2.5	45	46	110
VT-212	304	106	220	30	171.45	23	6-M16x105	34	6	61	48.75	12.75	163	133	5	18	36	50	M20x2.5	50	54	130
VIT-212	304	106	220	30	171.45	23	6-M16x105	34	6	61	48.75	12.75	163	133	5	18	36	50	M20x2.5	50	54	130
VT-215	381	114	300	43	235	29	6-M20x115	—	6	77.5	50.25	23.25	104	69	2	25.5	55	50	M30x3.5	60	63	165
VIT-218	450	114	300	43	235	29	6-M20x115	—	6	108	50.25	23.25	92	57	2	25.5	55	50	M30x3.5	60	63	165
VIT-224	610	125	380	60	330.2	31	8-M24x115	—	6	125	93.5	24.5	97	62	7.5	25	55	65	M30x3.5	60	76	180
VIT-232	810	135	380	80	330.2	26	8-M24x115	—	6	104.9	196.5	25.5	74	39	9	25	60	74	M30x3.5	60	97	210



V(40"-79") SERIES

SPECIFICATIONS:

3-JAW WEDGE TYPE NON THROUGH HOLE POWER CHUCK (WITHOUT ADAPTOR)

1. Chucking operations of very large components external or internal clamping.
2. Suitable for vertical machines thanks to the front protection of the slide ways.
3. Chuck with manual radial setting of master jaw for the workpiece.

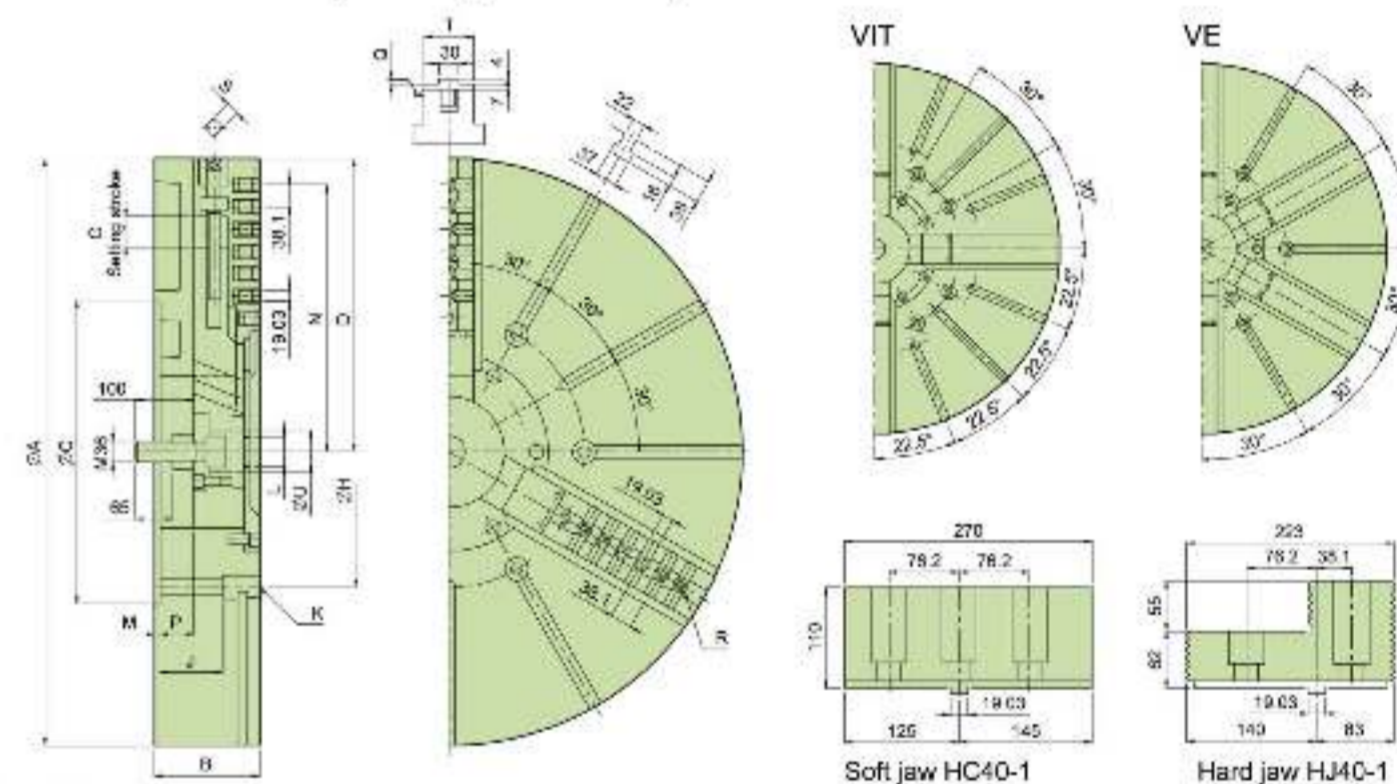

SPECIFICATIONS:

Model	Jaws	Plunger Stroke (mm)	Radial Jaw Stroke + (Manual setting)	Max. Pull Force (KN)	Max. Gripping Force (KN)	Max. Operating Pressure (kgf/cm ²)	Max. Speed (r.p.m.)	Weight (kg)	Moment of Inertia I (kg·m ²)	Matching Cylinder	Matching Hard Jaw	Matching Soft Jaw			
40" V-240	3	57	23 + (30)	180	320	42.8	630	645	82	MS250C	HJ40-1	HC40-1			
VIT-240	4												550	700	89
50" V-250	3	57	23 + (30)	180	320	42.8	500	890	168	MS250C	HJ40-1	HC40-1			
VIT-250	4												400	940	177
VE-250	6												360	971	183
63" VIT-263	4	60	24 + (40)	200	360	46.9	300	1700	518	MS250C	HJ40-1	HC40-1			
VE-263	6												280	1800	548
79" VE-279	6	60	24 + (40)	200	360	46.9	230	2850	1350	MS250C	HJ40-1	HC40-1			

DIMENSIONS:

Model	A	B	C	D max.	H	J	K	L	M	N max.	O	P max.	P min.	Q	R	S	T	U
40" V-240	1005	180	520	502	463.6	108	M24	M52x1.5	8	457	30	59	2	4	7-M24	19	85	72
VIT-240																		
50" V-250	1250	180	520	623	463.6	108	M24	M52x1.5	8	563	30	59	2	4	10-M24	19	85	72
VIT-250																		
VE-250																		
63" VIT-263	1600	220	720	796	647.6	144	M30	M52x1.5	8	738	40	82	22	6	13-M24	22	110	72
VE-263																		
79" VE-279	2000	238	720	996	647.6	159	M30	M52x1.5	8	914	40	100	40	6	17-M24	22	110	72



DOV / DON SERIES
SPECIFICATIONS:
VERTICAL AND VERTICAL / HORIZONTAL STATIONARY POWER CHUCKS



1. Suitable for vertical milling and drilling operations.
2. With large through-hole, Vertical/horizontal power chucks not only can grip the long workpiece but also can do horizontal holding.

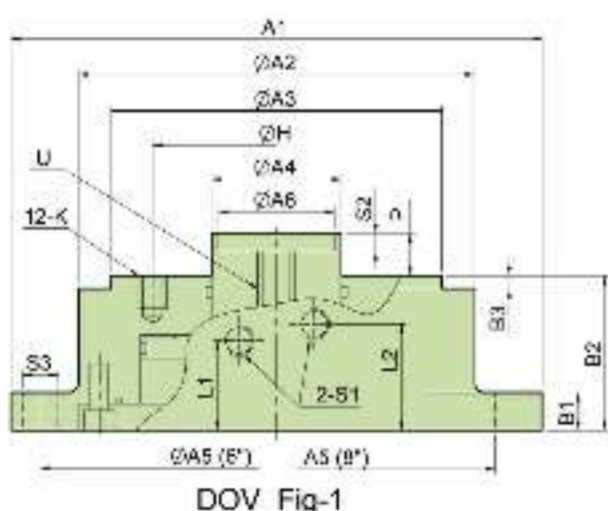

DOV Fig-1

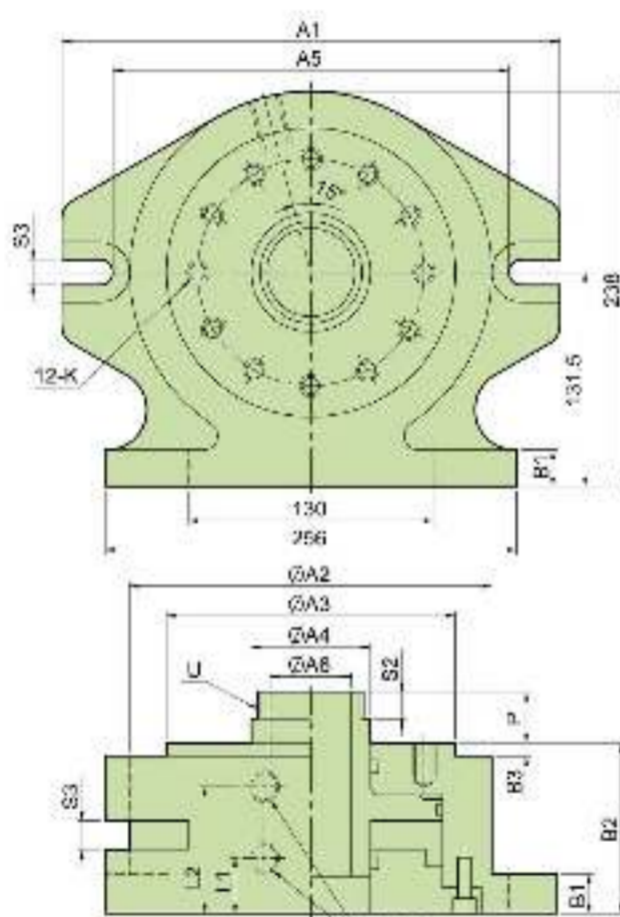

DON Fig-2

SPECIFICATIONS:

Dim	Model	Piston Dia (mm)	Piston Area		Piston Stroke (mm)	Max. Draw Bar Pull		Weight (kg)	Max. Operating Pressure (kgf/cm ²)	Matching Chuck
			Push Side(cm ²)	Pull Side(cm ²)		Push Side(kgf)	Pull Side (kgf)			
6"	DOV	φ115	104	78.5	20	1900	1400	12	20	V-206
8"	DOV	φ155	187	148.5	21	3600	2800	21	20	V-210
8"	DON	φ155	148.6	148.6	17	2800	2800	28.5	20	N-208

DIMENSION:

Model	A1	A2	A3	A4	A5	A6	B1	B2	B3	L1	L2	H	K	P Max.	P Min.	S1	S2	S3	U	Reference
6" DOV	φ220	168	140	55	φ200	49	16	65.5	5.5	38	45	104.78	12-M10X16L	18	-2	PT 1/4"	7.6	2-φ15	M16XP2.0	Fig-1
8" DOV	290	210	170	70	242	58	24	86	5.5	23	65	133.35	12-M12X18L	20	-1	PT 1/4"	5.5	2-16	M16XP2.0	Fig-1
8" DON	293	213	170	70	242	52	24	100	5.5	32.5	74.5	133.35	12-M12X18L	30.4	13.4	PT 1/4"	16	4-17	M60XP2.0	Fig-2



CR SERIES
SPECIFICATIONS:
COLLET CHUCKS FOR CYLINDRICAL CENTER MOUNT

1. Collet chucks with bayonet catch are mainly used for chucking bar work on NC/CNC lathes.
2. The bar stock can be fed in through the chuck.
3. Profiles can also be chucked with the appropriate collets.

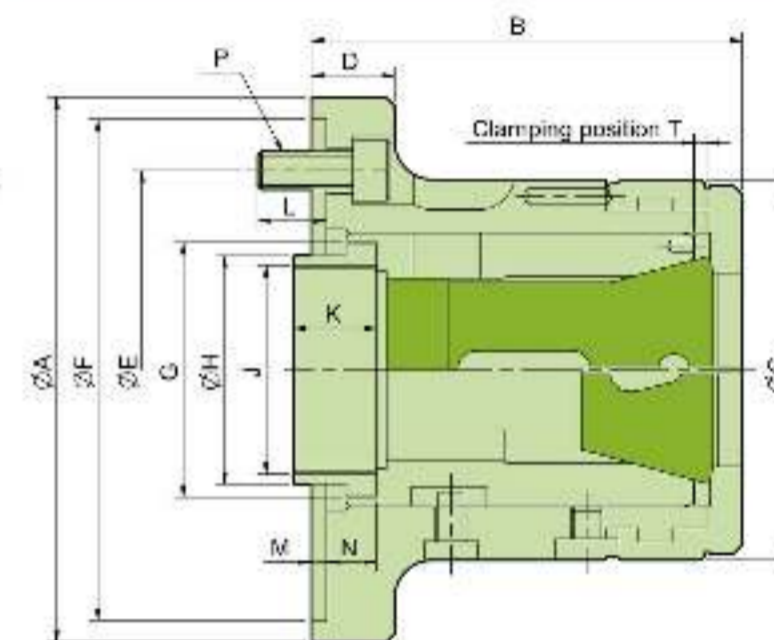

UNIT:mm

SPECIFICATIONS:

Model	Dim	Matching adapter	Bar Capacity (mm)	Sleeve Stroke (mm)	Weight (kg)	Max. operating force KN (kgf)	Max. gripping force KN (kgf)	Max. speed (r.p.m.)
CR42-140	140	140	42	7	6.2	25(2549)	55(5608)	6,000
CR60-170	170	170	60	7	11.5	30(3059)	65(6628)	5,000
CR60-220	220	220	60	7	15.5	30(3059)	65(6628)	5,000

DIMENSION:

Model	Dim	A(h6)	B	C	D	E	F(H6)	G	H	J max.	K	L	M	N	P	T
CR42-140	155	114	100	23	133.35	140	M66xP1.5	66	M55xP2.0	25	18	6	11.9	3-M10	3.1	
CR60-170	185	139	130	30	133.35	170	M90xP1.5	80	M74xP2.0	30	18	6	17.9	6-M12	3.1	
CR60-220	235	141	130	32	171.45	220	M90xP1.5	80	M74xP2.0	30	20	6	19.9	8-M16	3.1	

CAPACITIES:

CHUCK	MULTIBORE			SPRING COLLET		
	NO.	CAT.NO.	□	CAT.NO.	○	□
CR42	M-673	42	36 30	173E/4728	42	36 30
CR60	M-677	60	52 42	185E/4291	60	52 42

Collet Drawings:

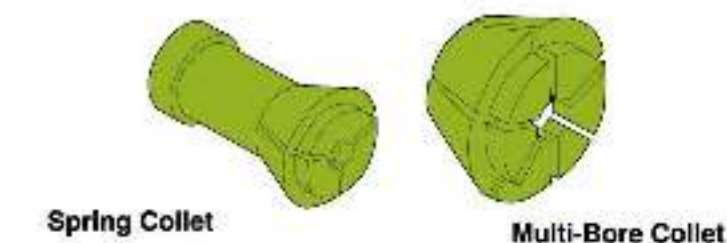

Uses the collet to DIN 6343 specification



CRA SERIES
SPECIFICATIONS:
COLLET CHUCKS FOR SHORT TAPER MOUNT

1. Collet chucks with bayonet catch are mainly used for chucking bar work on NC/CNC lathes.
2. The bar stock can be fed in through the chuck.
3. Profiles can also be chucked with the appropriate collets.

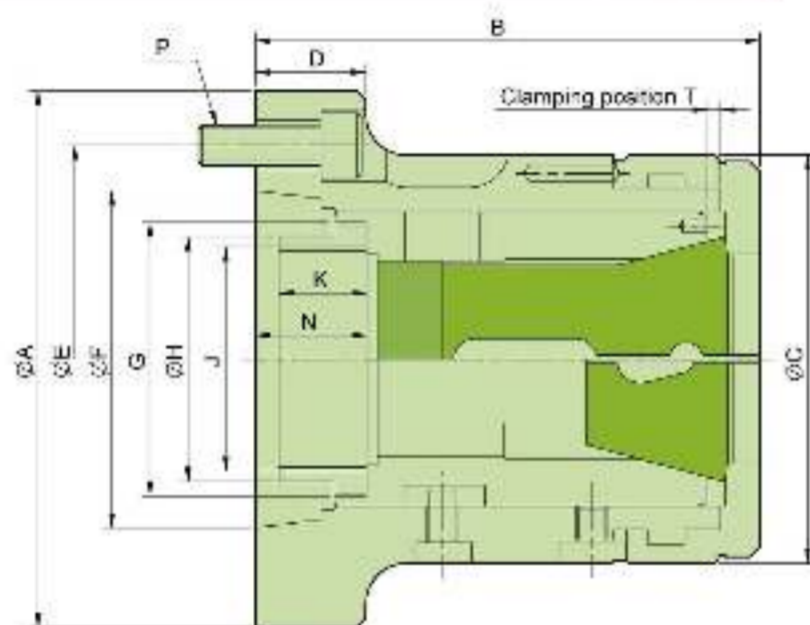

UNIT:mm

SPECIFICATIONS:

Model	Dim	Matching Spindle	Bar Capacity (mm)	Sleeve Stroke (mm)	Weight (kg)	Max. operating force KN (kgf)	Max. gripping force KN (kgf)	Max. speed (r.p.m.)
CR26A4	A2-4	A2-4	26	5	4.5	20(2039)	44(4486)	7,000
CR30A4	A2-4	A2-4	30	5	4.1	20(2039)	44(4486)	7,000
CR42A5	A2-5	A2-5	42	7	6.2	25(2549)	55(5608)	6,000
CR42A6	A2-6	A2-6	42	7	8.2	25(2549)	55(5608)	6,000
CR60A6	A2-6	A2-6	60	7	13	30(3059)	65(6628)	5,000
CR80A8	A2-8	A2-8	80	7	21	35(3568)	73(7443)	4,000

DIMENSION:

Model	Dim	A	B	C	D	E	F	G	H	J max.	K	N	P	T
CR26A4		112	103.5	85	30	82.55	63.513	M50xP1.5	45	M40xP1.5	15	21.7	3-M10	2.3
CR30A4		112	103.5	85	30	82.55	63.513	M50xP1.5	45	M40xP1.5	15	21.7	3-M10	2.3
CR42A5		135	124	100	27	104.78	82.583	M66xP1.5	60	M55xP2.0	25	27.4	4-M10	3.1
CR42A6		170	124	100	32	133.35	106.375	M66xP1.5	66	M60xP2.0	22	27.4	4-M12	3.1
CR60A6		170	145	130	27	133.35	106.375	M90xP1.5	80	M74xP2.0	30	29.9	4-M12	3.1
CR80A8		220	170	156	35	171.45	139.719	M114xP2.0	99	M90xP2.0	27.5	32.4	6-M16	6.1

CAPACITIES:

CHUCK	MULTIBORE			SPRING COLLET				
	NO.	CAT.NO.	Ø	Ø	Ø	Ø		
CR26	M-667	26	22	16	161E/6744	30	26	18
CR30	M-669	30	26	21	163E/4249	30	26	21
CR42	M-673	42	36	30	173E/4728	42	36	30
CR60	M-677	60	52	42	185E/4291	60	52	42
CR80	J-660	80	69	56	193E/H-47	80	69	56

Collet Drawings:

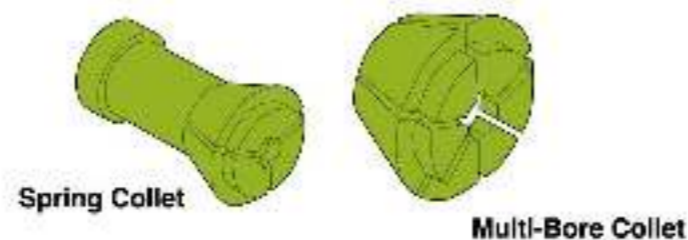

Uses the collet to DIN 6343 specification



HJ SERIES
SPECIFICATIONS:
HARD JAWS FOR HYDRAULIC POWER CHUCKS

1. Hard jaw for hydraulic power chucks.
2. Hard jaw for CNC lathe.

Fig-1

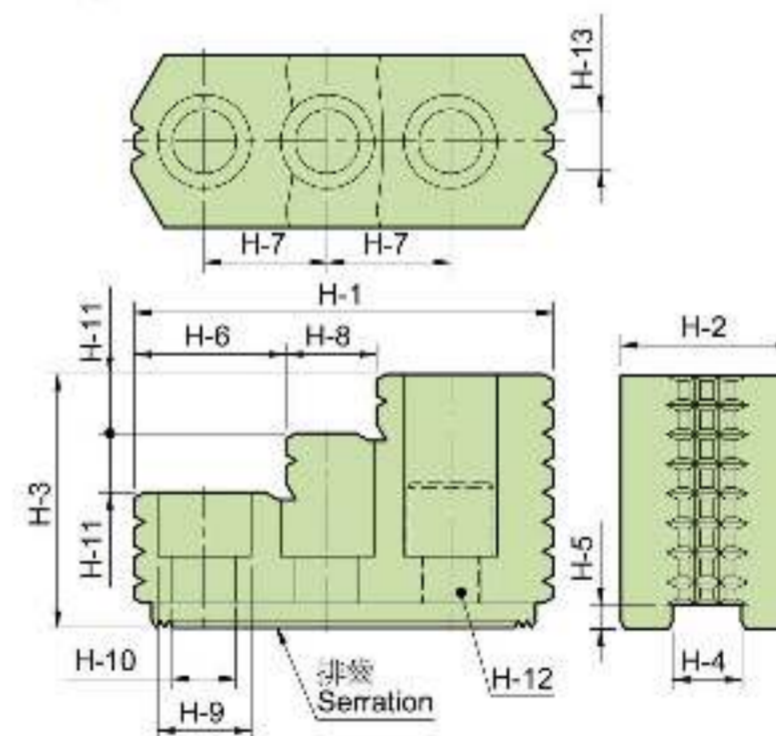
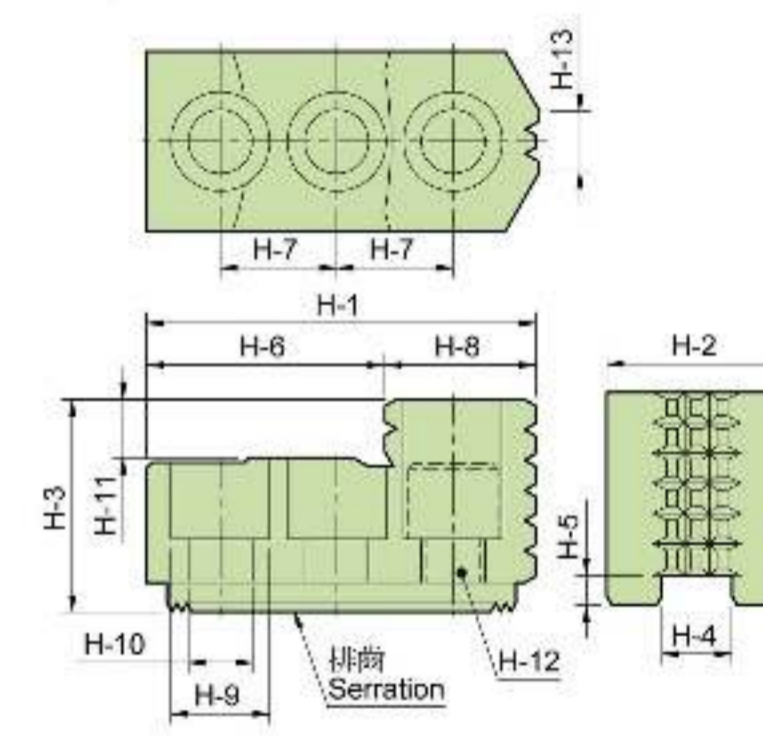

Fig-2



SPECIFICATIONS:

UNIT:mm

Model	H-1	H-2	H-3	H-4	H-5	H-6	H-7	H-8	H-9	H-10	H-11	H-12	H-13	Serration Pitch	Reference	Matching Chuck	3 Jaw Weight (kg)
HJ05	53	23	27.5	10	4	30.5	14	22.5	13.5	8.5	10	M8	6	1.5x60°	Fig-2	N-204.N-205	0.4
HJ06	67	31	36	12	5	39.5	20	27.5	17	11	10	M10	11	1.5x60°	Fig-2	N-206.V-206	1.0
HJ08	86	35	51	14	5	31	25	18	19	13	12	M12	12	1.5x60°	Fig-1	N-208.V-208	1.9
HJ10	99.5	40	54	16	5	43	30	17	19	13	13	M12	15	1.5x60°	Fig-1	N-210.V-210	2.9
HJ12	103	50	52	21	4	62.5	30	40.5	25	17	17	M16	30	1.5x60°	Fig-2	N-212	3.5
HJ12-1	103	50	52	18	5	62.5	30	40.5	22	15	17	M14	30	1.5x60°	Fig-2	V-212	3.6
HJ15	149	62	86	22	6	63	43	34	32	21	20	M20	40	1.5x60°	Fig-1	N-215.N-218	9.6
HJ15-1	149	62	86	25.5	5	63	43	34	32	21	20	M20	40	1.5x60°	Fig-1	V-215	9.5
HJ24-1	159.5	80	90	25	9	104.5	50	55	32	21	40	M20	55	3.0x60°	Fig-2	N-220.N-224.V-221.V-224	14.3



HC SERIES

SPECIFICATIONS:

SOFT JAWS FOR HYDRAULIC POWER CHUCKS

1.Soft jaws for hydraulic power chucks.
2.Soft jaw for CNC lathe.



T-NUTS SERIES

SPECIFICATIONS:

SUITABLE FOR POWER CHUCK

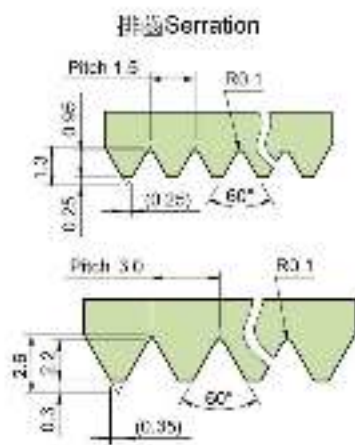
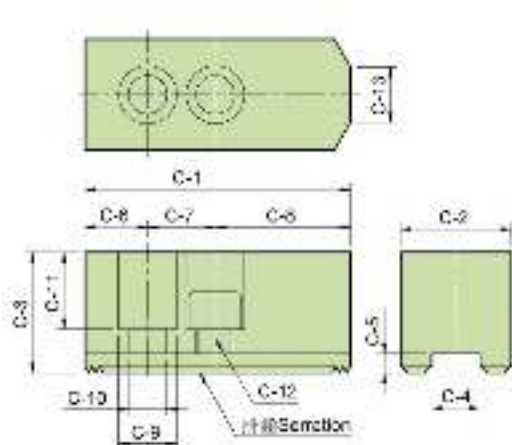

Fig. 1

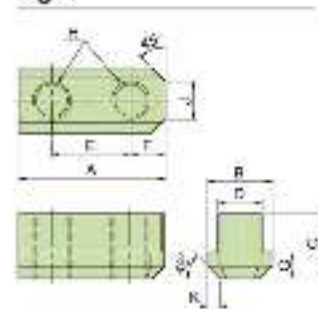

Fig. 2

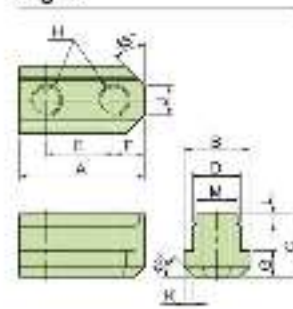
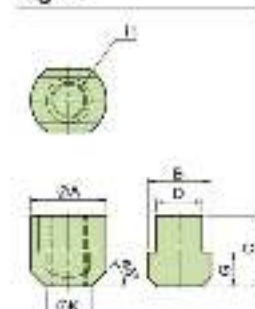

Fig. 3



SPECIFICATIONS:

UNIT:mm

Model	D1	D2	C6	C4	D5	D3	D7	C8	C9	D10	D11	C12	C13	Serration Pitch	Matching Chuck	Soft Jaw Weight (kg)
HC04	50	28	28	10	5	9	14	30	13.5	0	14	M5	5	1.5x10°	N-204	0.48
HC05	62	25	28	10	5	9	14	30	13.5	0	21	M5	5	1.5x10°	N-205	0.7
HC16	73	31	26	12	5	15	30	33	17	1	21	M10	4	1.5x10°	N-206, V-216	1.3
HC08	66	30	37	14	5	24	25	45	19	13	22	M12	16	1.5x10°	N-208, V-210	2.4
HC10	110	40	42	18	5	30	30	45	19	18	27	M12	18	1.5x10°	N-210, V-210	3.7
HC12	130	50	50	21	5	30	30	47	25	17	30	M16	22	1.5x10°	N-212	6.5
HC15	155	62	62	22	5	37	43	45	32	21	36	M20	-	1.5x10°	N-215, N-216	12.5
HC12-1	130	50	50	16	5	38	30	41	23	15	30	M14	23	1.5x10°	V-212	6.5
HC15-1	155	62	62	15.5	5	37	43	37	29	21	36	M20	-	1.5x10°	V-215, V-216	12.5
HC14-1	150	64	70	25	9	40	60	30	32	21	45	M20	-	3.0x10°	V-214, V-215, V-216	15.8
HC22-1	210	74	50	25	9	40	80	32	32	21	55	M20	-	3.0x10°	V-222	22.2

SPECIFICATIONS:

Model	A	B	C	D	E	F	G	H	J	K	L	N	Hg	Matching Chuck
NC005-0H	28	14.5	15	10	14	8	5.5	M8	8	2	-	-	1	N-204, N-205
NC005-0H	35	17.5	18.5	12	20	8.2	7.5	M10	8	2.5	-	-	1	N-206, NB-206
NC005-0H	40.5	20.5	20.5	14	25	10.5	8.5	M12	12	4	-	-	1	N-208, NB-208
NC010-0H	51	22.5	21.5	16	30	11	8.5	M12	11	3	-	-	1	N-210, NB-210
NC012-0H	56.5	25.5	27.8	21	30	12	11.3	M18	13	4.5	-	-	1	N-212, NB-212
NC015-0H	80	33.5	45.5	24	40	17	15.5	M20	11	5	B	22	2	N-215, N-216
VC206-CH	36.0	17.5	22.0	12	20	7.0	7.0	M10	6	3	-	-	1	V-206, N-T-206
VC208-CH	48	20.5	25.5	14	25	11	9.5	M12	8	4	-	-	1	V-208
VC210-CH	55	22.5	26.5	16	30	11	9.5	M12	8	4	-	-	1	V-210
VC212-CH	60.0	26.0	30.0	18	30	11.0	13.0	M14	12	5	-	-	1	V-212
VC216-CH	42	36	39.2	25.5	-	-	19	M20	-	25	-	-	3	V-215, V-216
VC215-CH	42	36	41.2	28	-	-	19	M20	-	25	-	-	3	V-215, V-216
VC224-CH	45	37.5	45	25	-	-	18	M20	-	26.0	-	-	3	N-206, N-214, V-215, V-216, V-217

SPECIFICATIONS:

Dim Model	Piston Dia. (mm)	Piston Area		Piston Stroke (mm)	Max. Draw Bar Pull Force		Max. Operating Pressure (kg/cm ²)	Max. Speed (r.p.m.)	Moment Inertia (kg·m ²)	Weight (kg)	Total Leakage (L/min)
		Push Side (cm ²)	Pull Side (cm ²)		Push Side KN(kgf)	Pull Side KN(kgf)					
M0928	90	53.2	43.3	10	19.9(2029)	18(1835)	40.8	8000	0.006	5.5	3.0
M1036	105	71	63.5	15	24.8(2529)	24(2447)	40.8	8000	0.011	8.6	3.0
M1236	125	100	89	15	38(3875)	33(3365)	40.8	7000	0.019	13.0	3.0
M1246	125	100	89	15	38(3875)	33(3365)	40.8	7000	0.019	12.0	3.0
M1546	155	161	154	22	60(6116)	57.8(5894)	40.8	6200	0.056	18	3.9
M1552	155	161	150	22	60(6116)	56(5710)	40.8	6200	0.052	16.8	3.9
M1868	180	198	197	25	74(7546)	73.5(7495)	40.8	4700	0.098	26.0	4.2
M1870	180	198	183	25	74(7546)	69(7036)	40.8	4700	0.085	25.5	4.2
M1875	180	198	183	25	74(7546)	69(7036)	40.8	4700	0.085	25.0	4.2
M1878	180	198	183	25	74(7546)	69(7036)	40.8	4700	0.085	25.5	4.2
M2085	205	252	234	30	94(9585)	88(8973)	40.8	3800	0.15	37.5	4.5
M2091	205	252	234	30	94(9585)	88(8973)	40.8	3800	0.15	37.0	4.5
M2511	250	348	336	23	124(12644)	120(12238)	40.8	2800	0.45	57	7.0



CM.B SERIES
SPECIFICATIONS:
HYDRAULIC CYLINDERS COOLANT COLLECTORS

1. Hydraulic Cylinders coolant collectors. Compact and light weight, they feature bore sizes up to 20% large than Conventional Cylinders. Precision finished piston bores and cool running rotary unions are included for years of trouble-free performance.
2. The sensors are extra ordered.

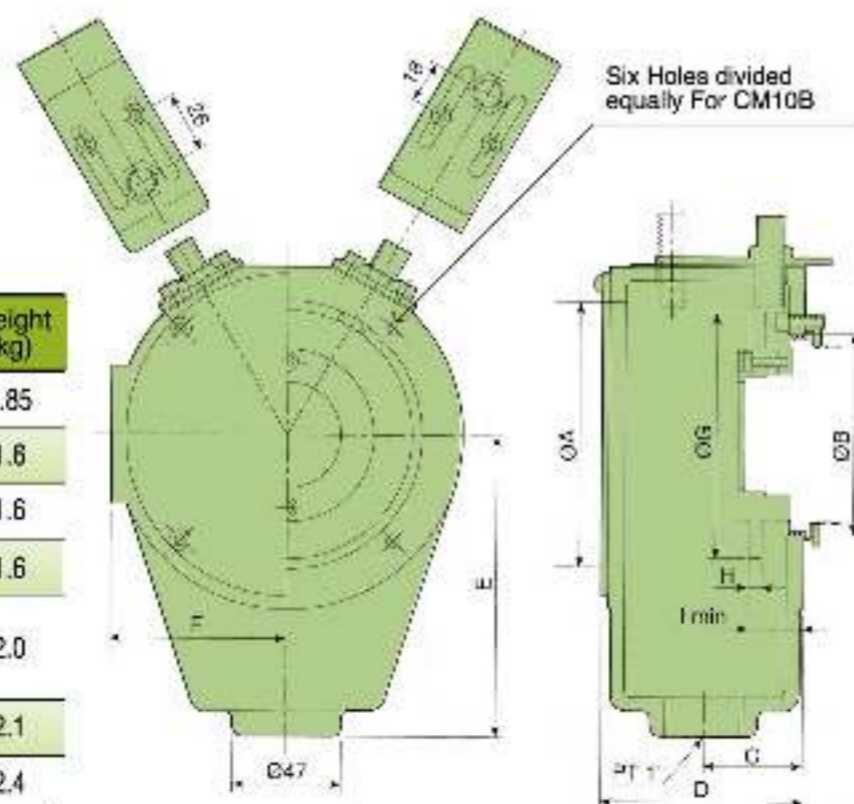

DIMENSIONS:

Dim Model	A	B	C	D	E	F	G	H	I	lmin	Matching cylinder	Weight (kg)
CM09B	85	67	33	70	105	55.5	77	5	24	M0928	0.85	
CM10B	118	75	42	84	131	76	107	5	22	M1036	1.6	
CM12B	118	87	42	84	131	76	107	5	23	M1236 M1246	1.6	
CM15B8	118	98	42	84	131	76	107	5	25.5	M1546 M1552	1.6	
CM18B	158	123	44	88.5	151	96	147	5	23	M1868 M1870 M1875 M1878	2.0	
CM20B	158	140	44	88.5	151	96	147	5	23	M2085 M2091	2.1	
CM25B	198	177	45	90	180	118	192	12	35	M2511	2.4	



MK SERIES
SPECIFICATIONS:
HIGH SPEED AND SHORT THROUGH HOLE ROTARY HYDRAULIC CYLINDER

1. The thin hydraulic cylinder which is short in length about 30% and light weight can reduce the spindle load while running in high speed.
2. Built-in check valve in safety auto lock and pressure relief valve in case of power failure occurs.
3. New model developed and rear and locking installation.

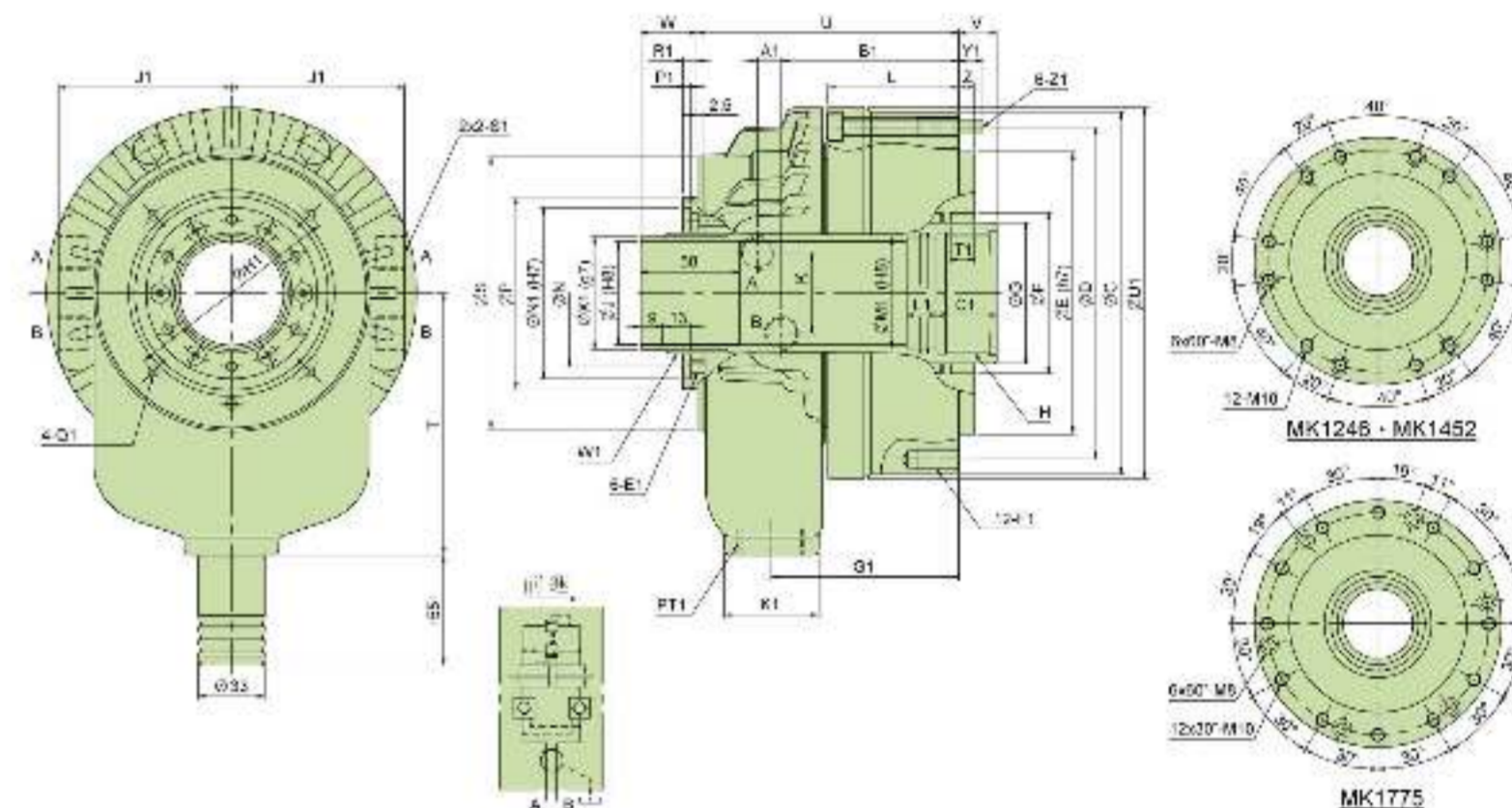

SPECIFICATIONS:

Model	Piston Dia (mm)	Piston Area		Piston Stroke	Max. Draw Bar Pull		Max. Operating Pressure (kg/cm ²)	Max. Speed (r.p.m.)	Moment of Inertia (kg·m ²)	Weight (kg)	Total Leakage (L/min)
		Push Side (cm ²)	Pull Side (cm ²)		Push Side KN(kgf)	Pull Side KN(kgf)					
MK-1246	128	102.6	91.4	16	43.6(4466)	38.9(3967)	4.5(45.9)	8000	0.017	8.6	3.1
MK-1452	145	135	122.6	22	26.5(5761)	52.1(5313)	4.5(45.9)	6500	0.028	12	3.9
MK-1775	170	166	152	25	70.7(7209)	64.7(6587)	4.5(45.9)	5500	0.060	17.8	4.5

DIMENSIONS:

Model	C	D	E	F	G	H	J	K	L	N	P	S	T	U	V Max.	V MIN.	W Max.	W MIN.	Z
MK-1246	162	147	130	75	65	M 5.5 x 2.0	43	40	56	64	85	116	120	120	13	-3	44	26	8
MK-1452	184	185	140	80	70	M 6.0 x 2.0	52	40	66	73	96	135	130	130	19	-3	47	25	8
MK-1775	212	195	180	105	90	M 6.5 x 2.0	75	46	71	98	121	164	160	157	22	-3	50	25	8

Model	A1	B1	C1	E1	F1	G1	H1	J1	K1	L1	M1	M1	N1	P1	Q1	R1	S1	T1	U1	W1	X1	Y1	Z1
MK-1246	8.5	79.5	25	M6x10L	M10x20L	84	98	76	47	15	50	50	78	4	M5x8L	9	PT3/8	12	165	M52x1.5	50	15	M8
MK-1452	9	88	30	M6x7L	M10x20L	93	110	86	47	15	55	55	85	4	M6x8L	7	PT3/8	12	164	M58x1.5	56	12	M8
MK-1775	17.5	99	30	M6x13L	M10x20L	110	155	100	47	15	80	80	108	4	M6x10L	7	PT1/2	12	216	M84x2.0	81	18	M10



ML-CM.B SERIES
SPECIFICATIONS:
EXTRA LARGE THROUGH HOLE ROTARY HYDRAULIC CYLINDER

1. Matching for large bore power chucks.
2. Special aluminum alloy steel body, light weight for reducing the spindle load.
3. Valves inside to maintain the power of pushing.
4. Extra large bore design, equipped with coolant collector and detective plate.
5. Sensors and mounting bolts are extra order.



MS SERIES
SPECIFICATIONS:
NON THROUGH HOLE ROTARY HYDRAULIC CYLINDER (WITH VALVES)

Built-in safety check valves.

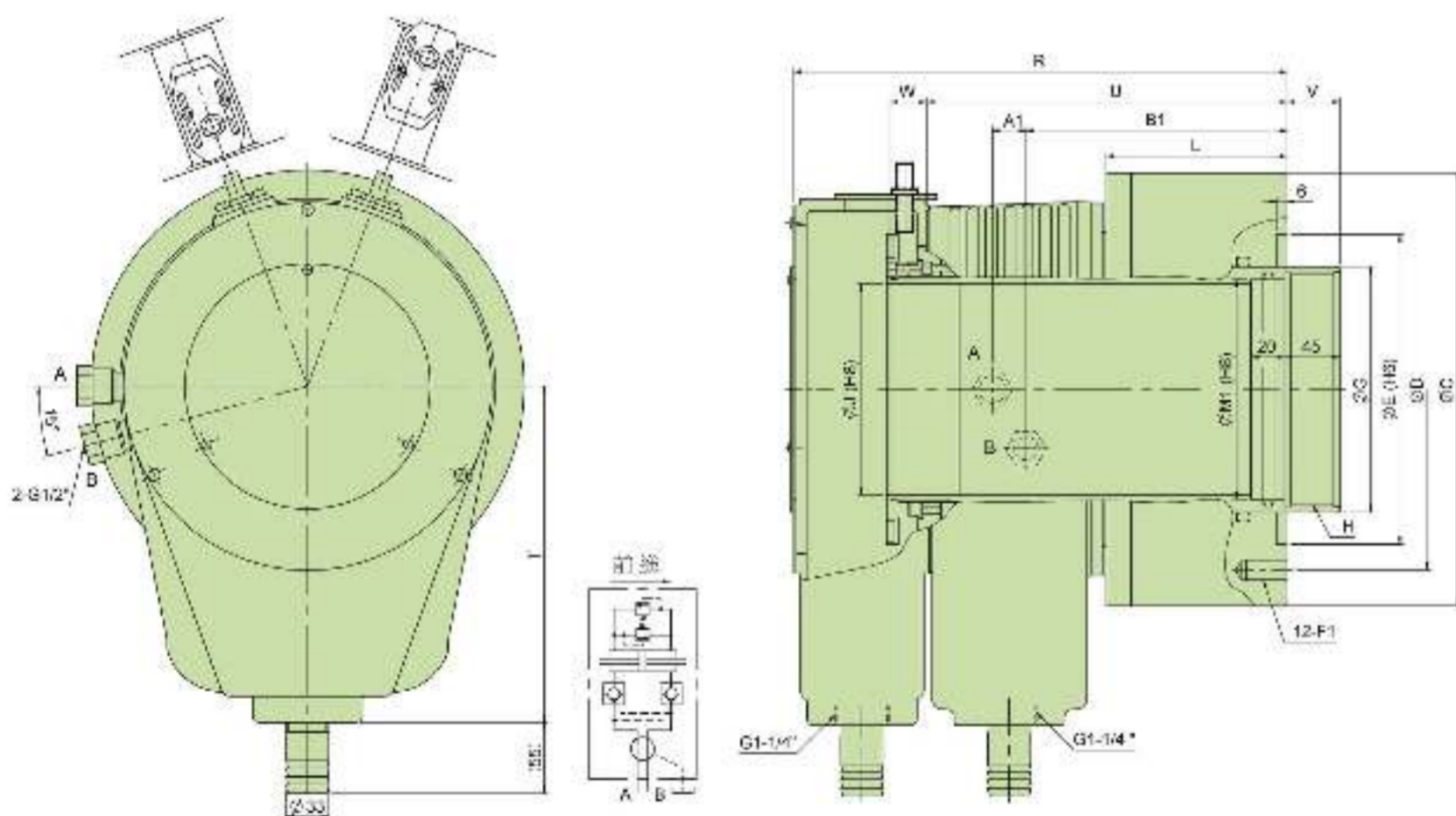

SPECIFICATIONS:

Model	Piston Dia (mm)	Piston Area		Piston Stroke	Max. Draw Bar Pull		Max. Operating Pressure (kgf/cm ²)	Max Speed (r.p.m.)	Moment of Inertia I (kg·m ²)	Weight (kg)	Total Leakage (L/min)
		Push Side (cm ²)	Pull Side (cm ²)		Push Side KN/gf	Pull Side KN/gf					
ML2816CM28B	285	394	350	42	116.8(11910)	106.8(10584)	3.3(33.6)	2000	0.85	68	9
ML3320CM33B	335	515.7	416.9	42	152.9(15591)	136.9(13960)	3.3(33.6)	1600	1.09	103	10

DIMENSIONS:

Model	C	D	E	G	H	J	L	R	T	U	V max.	V min.	W max.	W min.	A1	B1	F1	M1
ML2816CM28B	335	280	240	190	M180x3.0	166.5	140	362	280	279	41	-1	67	25	18	202	M16x32L	170
ML3320CM33B	390	320	280	230	M215x3.0	205	147	392	260	292	41	-1	67	25	18	210	M20x32L	210

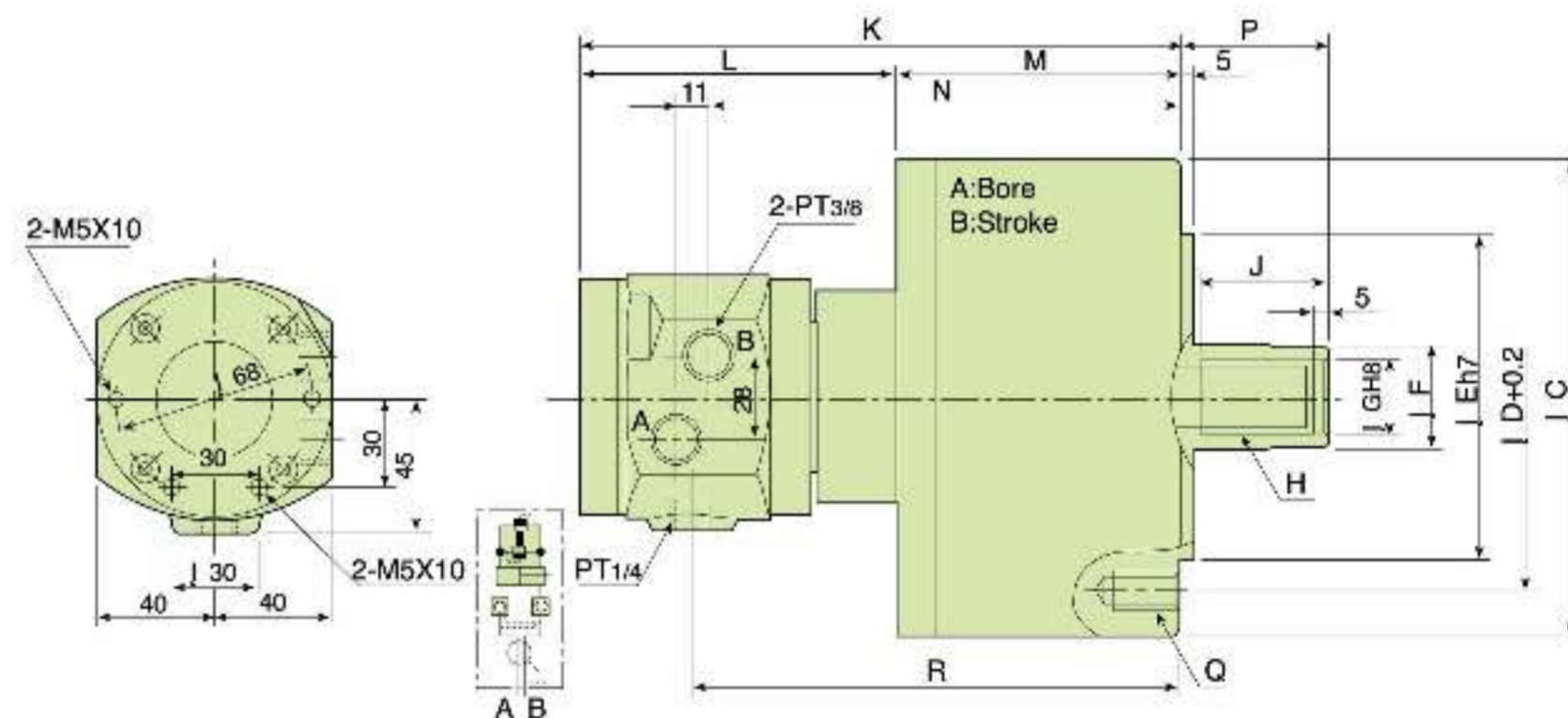

DIMENSIONS:

Model	A	B	C	D	E	F	G	H	J	K	L	M	N	P max.	P min.	Q	R
MS105	105	20	135	100	80	30	21	M20x2.5	35	197	108	89	152	45	25	6-M10x20	158
MS125	125	25	160	130	110	35	25	M24x3.0	44	205	108	97	160	51	26	6-M12x24	166
MS150	150	30	190	130	110	45	31	M30x3.5	45	214	108	106	169	56	26	12-M12x24	175
MS200	200	35	245	145	120	55	37	M36x4.0	60	228	108	120	183	69	34	12-M16x30	189

SPECIFICATIONS:

Model	Dim	Piston Area		Mar. Draw Bar Pull	Piston Stroke	Max. Speed	Max. Operating Pressure	Total Leakage	Moment Inertia	Weight
		Push Side (cm ²)	Pull Side (cm ²)	Pull Side KN (kgf)	(mm)	(r.p.m.)	(kgf/cm ²)	(L/min)	I (kg·m ²)	(kg)
MS105		86	79	29 (2957)	20	6000	4.0(40.8)	0.8	0.0125	7.1
MS125		122	113	42 (4283)	25	6000	4.0(40.8)	0.8	0.0225	10
MS150		176	160	60 (6118)	30	5500	4.0(40.8)	0.8	0.0475	13.5
MS200		314	290	108 (11013)	35	5500	4.0(40.8)	0.8	0.0975	22



MF-C / MS-C SERIES
SPECIFICATIONS:
NON THROUGH HOLE ROTARY HYDRAULIC CYLINDER (WITH VALVES AND SWITCHES)

1. Built-in safety check valves.
2. Pressure relief valves and sensor switches.
3. The sensors are extra ordered.

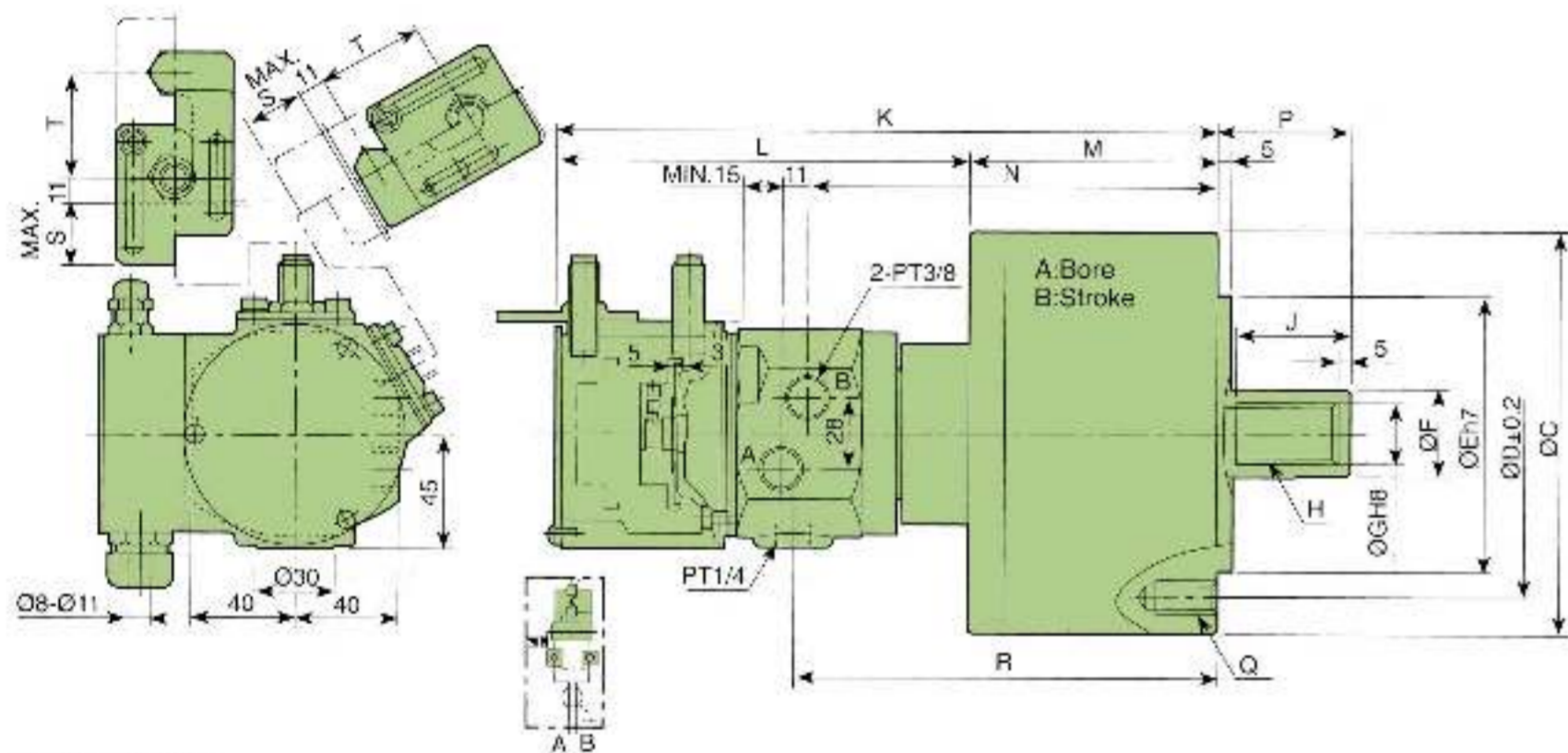

DIMENSIONS:

Model	A	B	C	D	E	F	G	H	J	K	L	M	N	P max.	P min.	Q	R	S	T
MS105C	105	20	135	100	80	30	21	M20x2.5	35	257	168	89	152	45	25	6-M10x20	158	23	46
MS125C	125	25	160	130	110	35	25	M24x3.0	44	265	168	97	160	51	28	6-M12x24	166	23	46
MF125C	125	35	160	130	110	35	25	M24x3.0	44	269	168	101	164	57	22	6-M12x24	170	23	46
MS150C	150	30	190	130	110	45	31	M30x3.5	45	274	168	106	169	56	28	12-M12x24	175	23	46
MS200C	200	35	245	145	120	55	37	M36x4.0	60	288	166	120	183	69	34	12-M16x30	189	28	46

SPECIFICATIONS:

Model	Dim	Piston Area Push Side (cm ²)	Piston Area Pull Side (cm ²)	Max. Draw Bar Pull Pull Side KN (kgf)	Piston Stroke (mm)	Max. Speed (r.p.m.)	Max. Operating Pressure (kgf/cm ²)	Total Leakage (L/min)	Moment of Inertia I (kg·m ²)	Weight (kg)
MS105C		84	79	29 (2957)	20	6000	4.0(40.8)	0.8	0.0125	7.6
MS125C		120	113	42 (4283)	25	6000	4.0(40.8)	0.8	0.022	10.5
MF125C		120	113	42 (4283)	35	6000	4.0(40.8)	0.8	0.022	10.5
MS150C		174	160	60 (6118)	30	5500	4.0(40.8)	0.8	0.047	14
MS200C		312	290	108 (11013)	35	5500	4.0(40.8)	0.8	0.097	22.5

● Draw bar pull force: Pressure 4.0 MPa(40.8kgf / cm²)
 ● Total leakage: Pressure 3.0 Mpa (30.6 kgf / cm²) and of temperature 50°C
 ● Proximity switch: Model BESS 16-329-E4-Y (BALLUFF) DC 12/24V 200mA NPN



MS250C/MS300C SERIES
SPECIFICATIONS:
NON THROUGH HOLE ROTARY HYDRAULIC CYLINDER (WITH VALVES AND SWITCHES)

1. Through-hole for coolant, oil or air with thread for rotary union.
2. Mounting from the rear or from the front side.
3. Built-in safety check valves and bracket for proximity switch.
 (The proximity switches are extra ordered.)

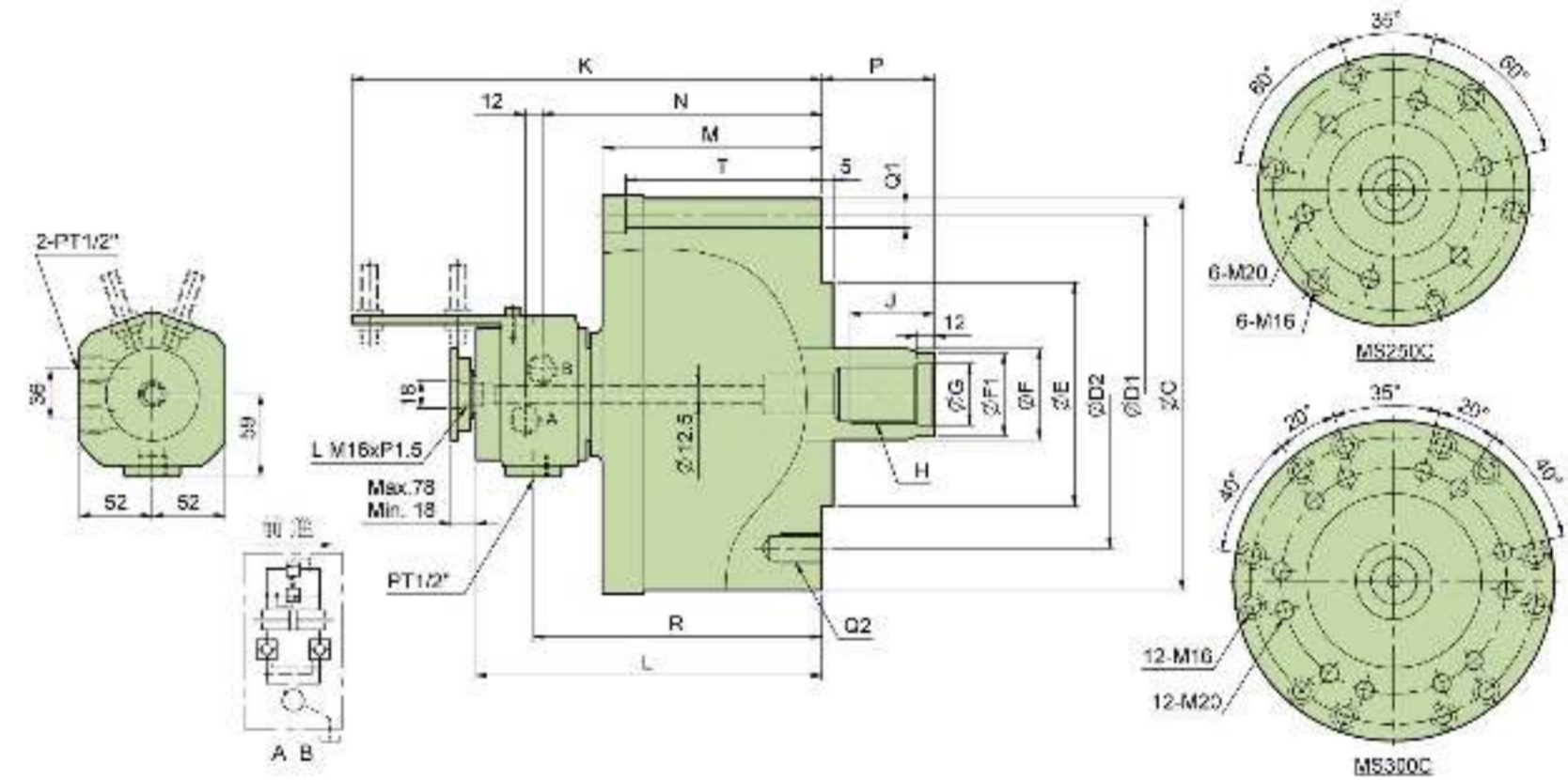

DIMENSIONS:

Model	C	D1	D2	E (h7)	F	F1	G	H	J	K	L	M	N	P max.	P min.	Q1	Q2	R	T
MS250C	300	275	220	160	65	62	44	M42x3.0	60	356	267	177	220	65	25	6-φ17	6-M20	226	160
MS300C	355	330	270	210	75	70	50	M48x3.0	70	359	270	182	223	65	25	12-φ17	12-M20	229	165

SPECIFICATIONS:

Model	Piston Dia (mm)	Piston Area Push Side (cm ²)	Piston Area Pull Side (cm ²)	Max. Draw Bar Pull Push Side (KN/kgf)	Max. Draw Bar Pull Pull Side (KN/kgf)	Piston Stroke (mm)	Max Speed (r.p.m.)	Max. Operating Pressure (kgf/cm ²)	Total Leakage (L/min)	Moment of Inertia I (kg·m ²)	Weight (kg)
MS250C	250	481.5	453.6	227(23147)	214(21822)	60	2000	50	2	0.67	78
MS300C	300	697.5	656.6	282(26716)	247(25166)	60	1500	40.8	3	1.60	106



MH SERIES
SPECIFICATIONS:
NON THROUGH HOLE ROTARY HYDRAULIC CYLINDER

1. Compact, low inertia, light weight cylinder:
 Manufactured aluminium alloy, this cylinder is lightweight design and reduce the weight on the machine spindle.
2. High speed:
 This balanced design cylinder is light weight and compact and maintains outstanding stability during high speed operation.
3. Long life:
 High quality cylinder seals and high accuracy surface finish on parts ensure the long life of these cylinders.

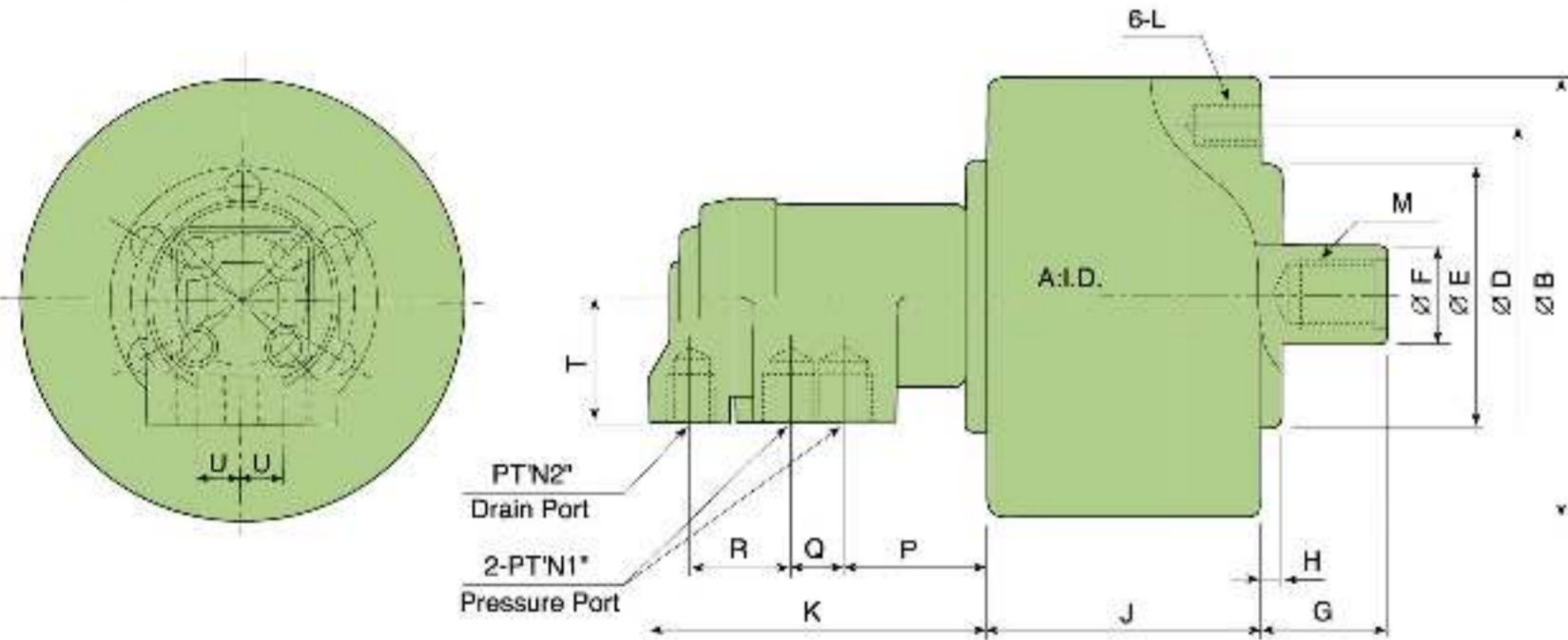

DIMENSIONS:

Dim Model	A I.D.	B	D	E (h7)	F	G Max. Min.	H	J	K	L	M	N1	N2	P	Q	R	T	U
MH80	80	115	90	65	25	45 30	8	73.5	103	M8x1.25 18	M16x2.0x32	3/8"	1/4"	46	15.5	30.5	38	13
MH100	100	135	100	80	25	45 25	8	89.5	103	M10x1.5 19	M16x2.0x32	3/8"	1/4"	46	15.5	30.5	38	13
MH125	125	180	130	110	30	51 26	8	95.5	103	M12x1.75 18	M20x2.5x32	3/8"	1/4"	46	15.5	30.5	38	13
MH150	150	190	130	110	45	50 20	8	107	103	M12x1.75 20	M30x3.5x35	3/8"	1/4"	46	15.5	30.5	38	13

SPECIFICATIONS:

Model	Dim	Piston Area		Mar. Draw Bar Pull Side KN (kgf)	Piston Stroke (mm)	Max. Speed (r.p.m.)	Max. Operating Pressure (kgf/cm ²)	Moment Inertia I (kg·m ²)	Weight (kg)
		Push Side (cm ²)	Pull Side (cm ²)						
MH80		47.7	42.8	13.9 (1417)	15	6000	35	0.005	5.1
MH100		75.4	70.5	22.9 (2335)	20	5500	35	0.0125	6.6
MH125		121.1	114	37 (3773)	25	5500	35	0.02	8.4
MH150		176	160	60 (6118)	30	4000	40	0.047	10.4



HB4 SERIES
SPECIFICATIONS:
BORING MILL JAWS

1. Clamping of workpiece for larger size lathe, vertical lathe, die set with jig.
2. One set of 4-piece bolts with T-bolt.

HB4-160 SPECIFICATIONS:

Jaw stroke (mm)	50
Max. gripping force (KN)	39.2
weight (kg)	29

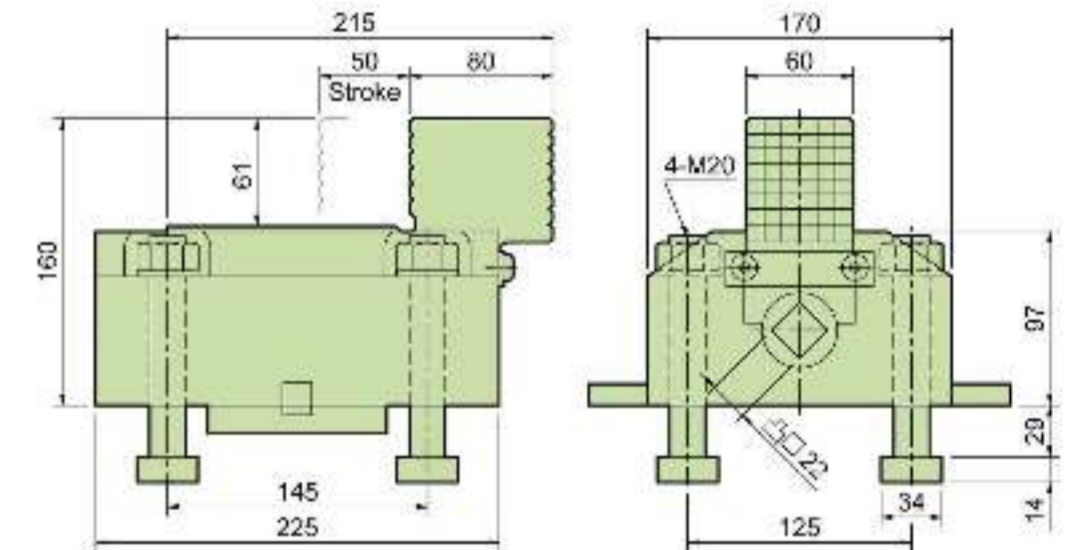

HB4-189 SPECIFICATIONS:

Jaw stroke (mm)	50
Max. gripping force (KN)	39.2
weight (kg)	31

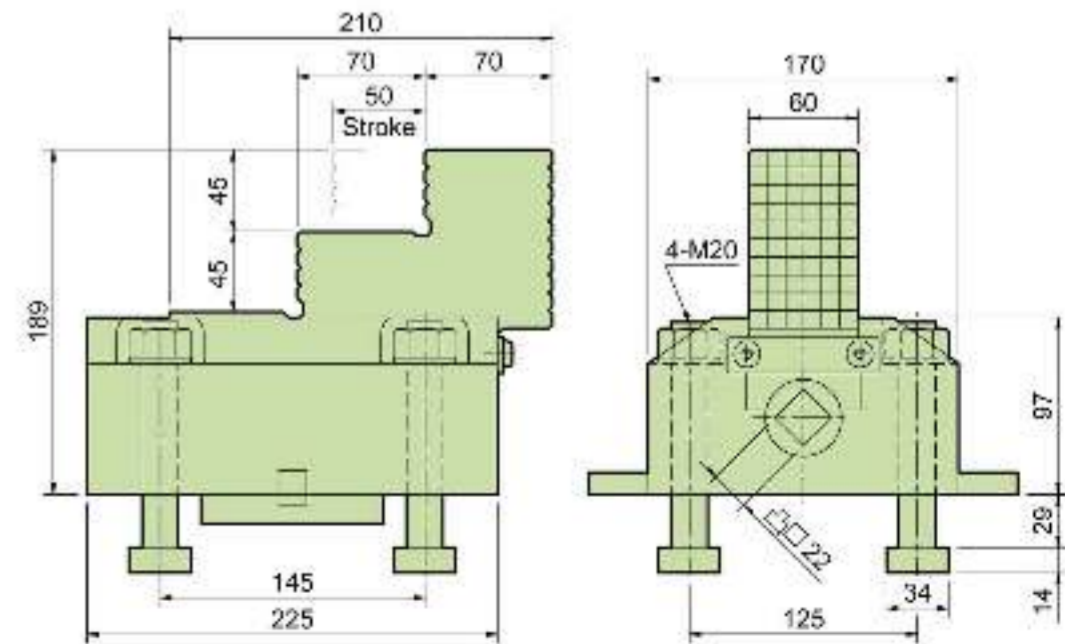



F52 SERIES

SPECIFICATIONS:

HIGH SPEED AND LIGHT WEIGHT TYPE STRONG FINGER CHUCK FOR ALUMINUM WHEELS

1. All sliding surfaces are hardened and ground and ground for accurate actual running and long service repeatability.
2. Mounting:
Adaptor mounting to fit with DIN, ISO, BS, ASA, B5-9 type A spindles.

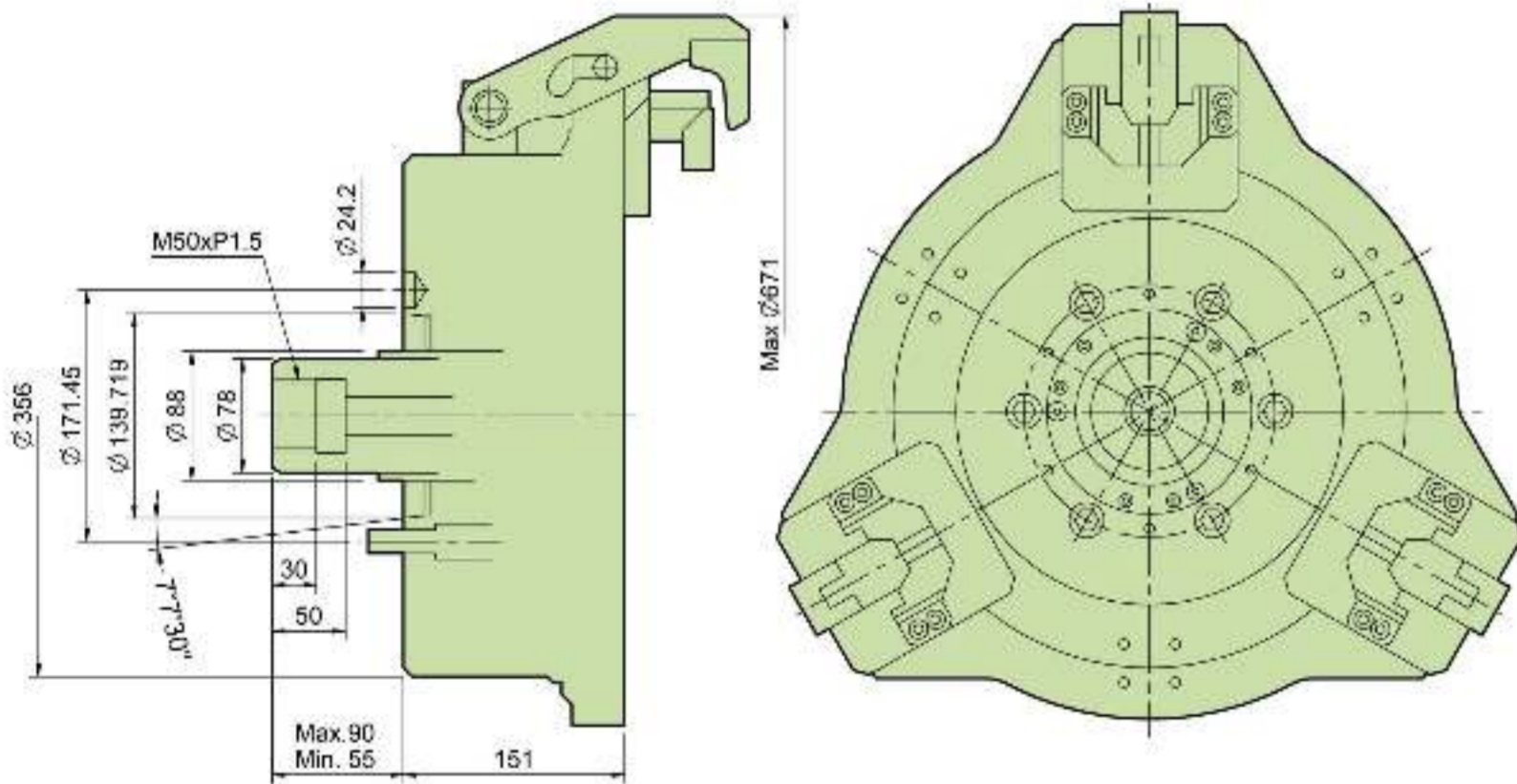

SPECIFICATIONS:

Model	Dim	Applicable Wheel Size	Out Dia Of Chuck(mm)	Available Spindle Nose	Gripping Force (kgf)	Max. Speed (r.p.m.)	Weight (Without Jigs)(kg)	Matching Cylinder
F52A8		12"-18"	521	A2-8	3300	2800(18"2200)	98	MS200C



F61 SERIES

SPECIFICATIONS:

HIGH SPEED AND LIGHT WEIGHT TYPE STRONG FINGER CHUCK FOR ALUMINUM WHEELS

1. All sliding surfaces are hardened and ground and ground for accurate actual running and long service repeatability.
2. Mounting:
Adaptor mounting to fit with DIN, ISO, BS, ASA, B5-9 type A spindles.

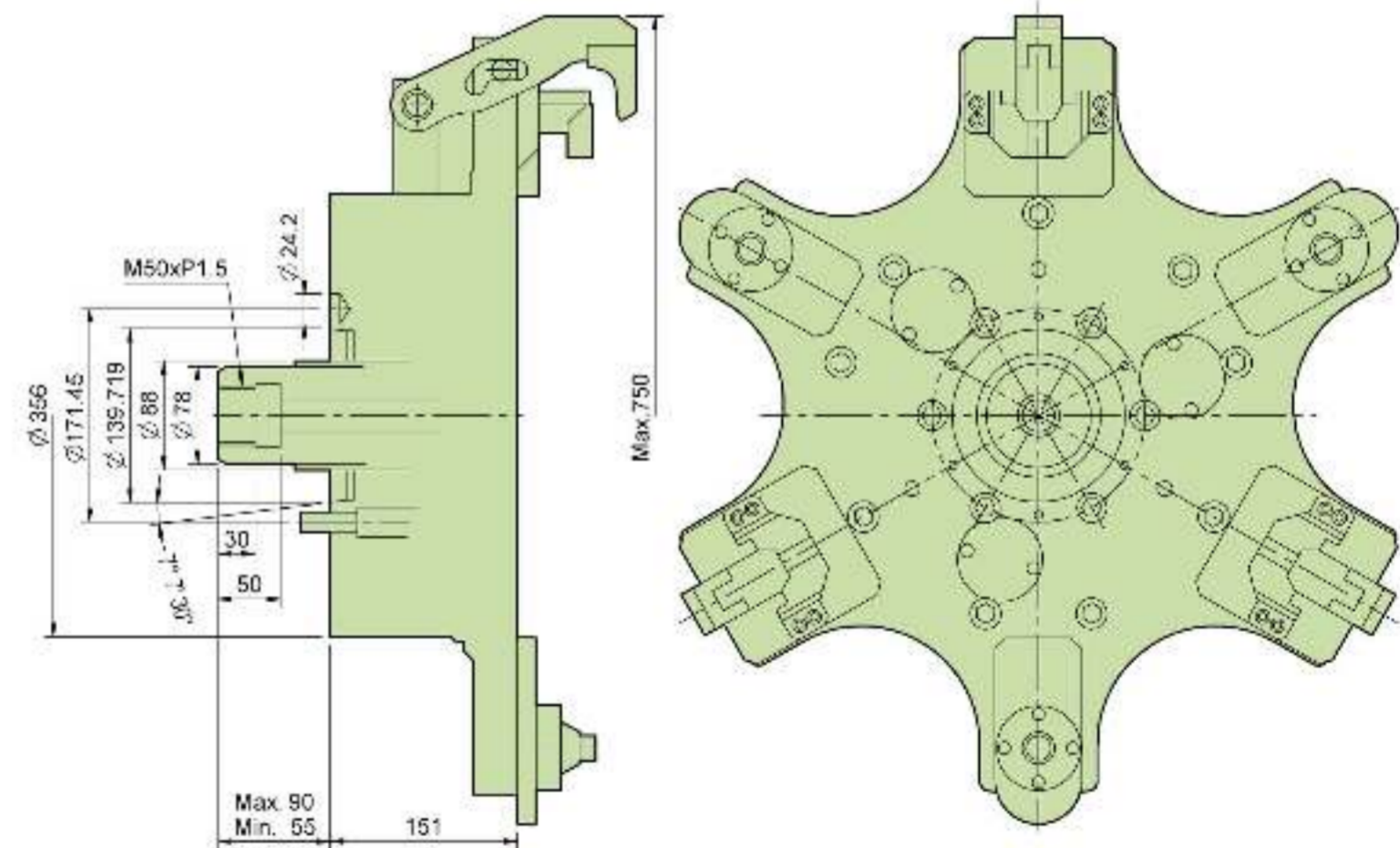

SPECIFICATIONS:

Model	Dim	Applicable Wheel Size	Out Dia Of Chuck(mm)	Available Spindle Nose	Gripping Force (kgf)	Max Rpm Speed (r.p.m.)	Weight (Without Jigs)(kg)	Matching Cylinder
F61A8		13"-22"	610	A2-8	3300	1500	145	MS200C

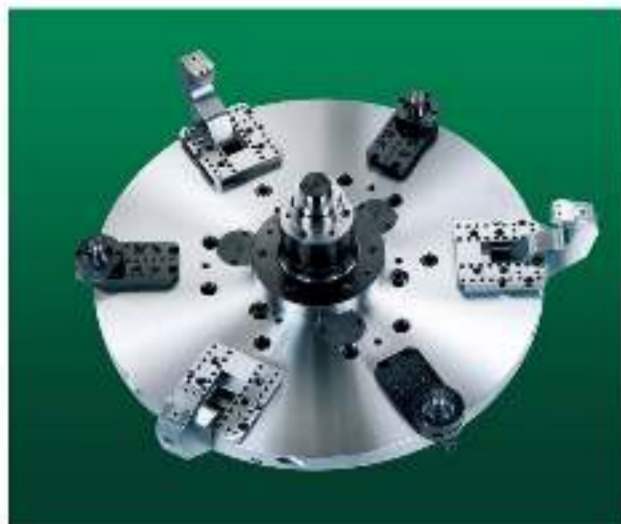

F66 SERIES
SPECIFICATIONS:
HIGH SPEED AND LIGHT WEIGHT TYPE STRONG FINGER CHUCK FOR ALUMINUM WHEELS

1. All sliding surfaces are hardened and ground for accurate actual running and long service repeatability.
2. Mounting:
 Adaptor mounting to fit with DIN, ISO, BS, ASA, B5-9 type A spindles.

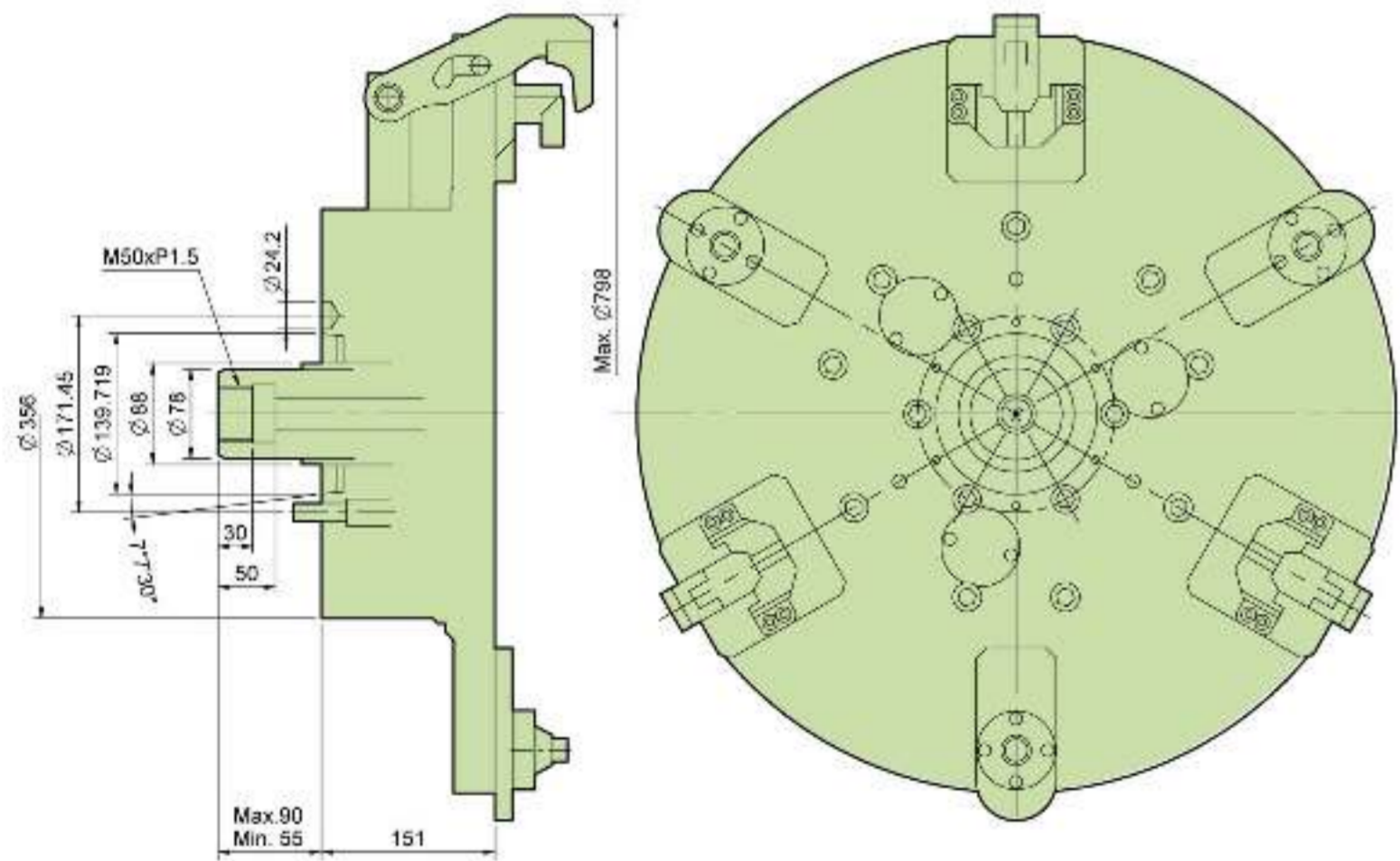

SPECIFICATIONS:

Model	Dim	Applicable Wheel Size	Out Dia Of Chuck(mm)	Available Spindle Nose	Gripping Force (kgf)	Max Speed (r.p.m.)	Weight (Without Jlgs)(kg)	Matching Cylinder
F66A8		19"-24"	660	A2-8	3300	1500	182	MS200C



BL SERIES
SPECIFICATIONS:
3-JAW BALL SWING LOCK CHUCK

1. The chuck can attract the work and hold it on.
 The jaw operates in two stages: fastening → drawing in, so it can hold the work exactly on the locator in front of the chuck, and make it under the stable situation.
2. The chuck can grasp the work on both outside diameter and inside diameter. The chuck can switch between outside diameter mode and inside diameter mode by a simple operation.
3. The chuck can grasp the part of the taper. The chuck can exactly grasp the black surface of the cast irons, which has draft. So the discard process can be ignored on the chucking part of the work. (It can grasp up to a 20 degree taper when using a clipper.)
4. The jaw can equalize. The jaw can equalize on the outside diameter, so it can grasp the work steadily. (Jaw self-equalizing to max 5°)
5. Dustproof performance is excellent. It is different from a past general purpose chuck. It is structurally dustproof. Especially there is a dustproof seal in the part of lock arm to prevent the dust.

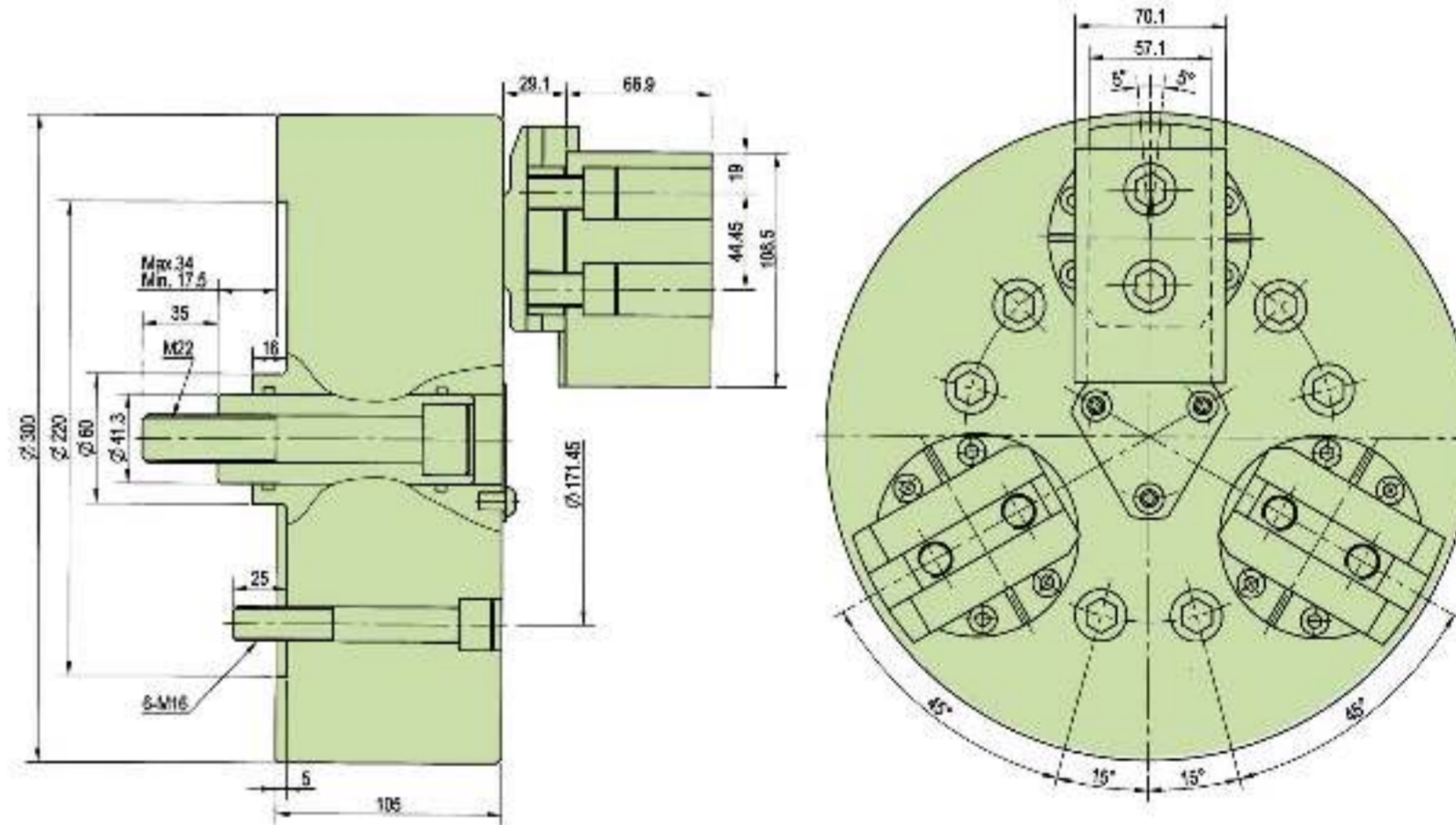

SPECIFICATIONS:

Model	Plunger Stroke (mm)	Jaw Stroke Diameter (mm)	Max. Draw Bar Pull Force KN (kgf)	Max. Gripping Force KN (kgf)	Max. Operating Pressure MPa (kgf/cm ²)	Max. Speed (r.p.m.)	Weight (with jaw) (kg)	Moment of Inertia I (kg·m ²)	Matching Cylinder
BL-12	17.5	12.4	40.7(4152)	122(12440)	2.8(28.5)	2800	65	0.18	MS150C



DR SERIES
SPECIFICATIONS:
3-JAW DRAW DOWN POWER CHUCK

Draw Down power chuck feature of radial gripping will lead to almost no work piece uplifting displacement; for machining casting and forging part:

1. For the gripped work piece is appressed to the surface, chucks are suitable for heavy machining.
2. Chuck Actutors with cylindrical structure are durable and ensures high gripping repeatability.
3. Accurate self-centering and pull back features are adequate for precise length control machining requirements.

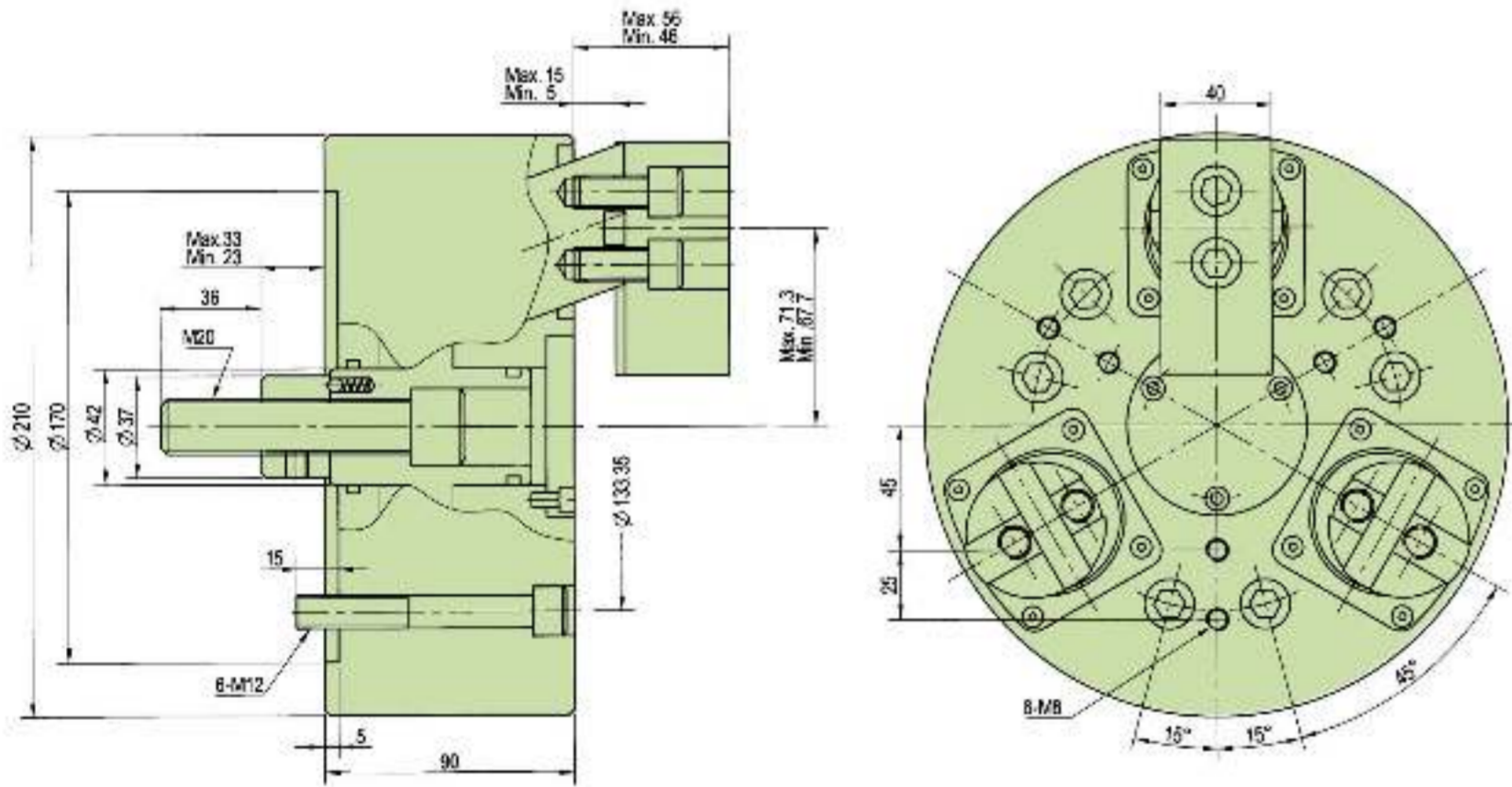

P165 SERIES
SPECIFICATIONS:
FLOATING PLATE CENTER CHUCK

Suitable for easy one step cutting of thin holes, plate and outside diameter.

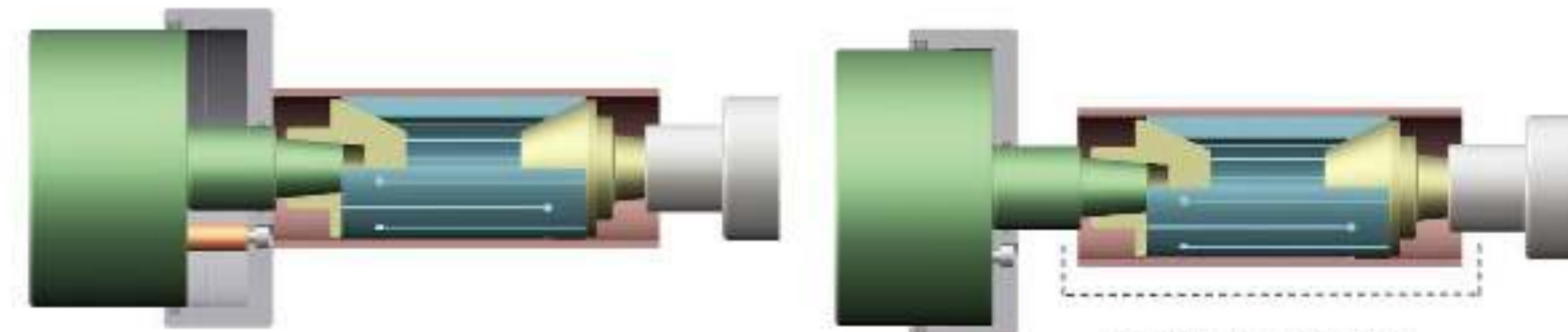
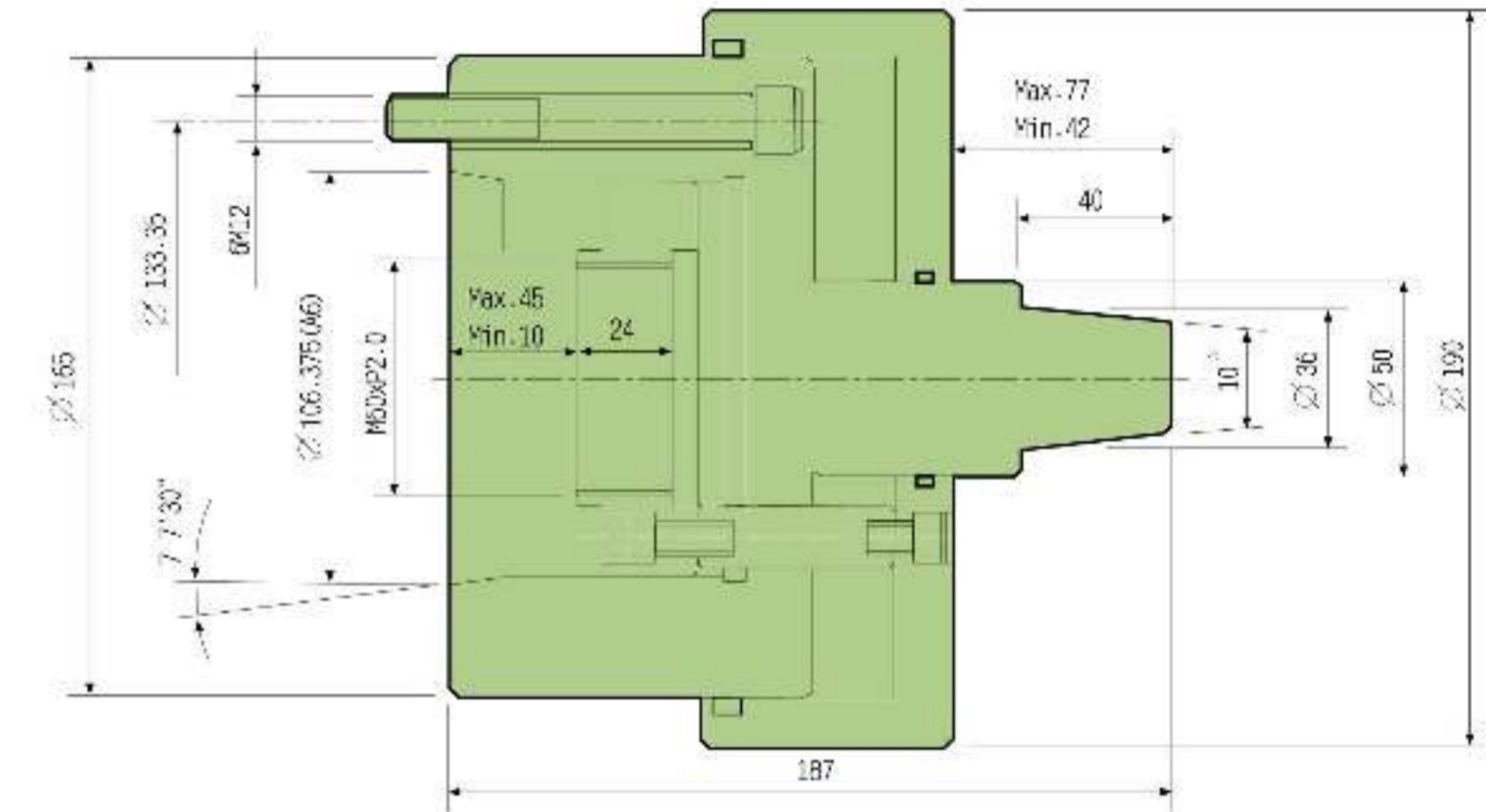

Possible processing range.

SPECIFICATIONS:

Model	Plunger Stroke (mm)	Jaw Stroke Diameter (mm)	Max. Draw Bar Pull Force KN (kgf)	Max. Gripping Force KN (kgf)	Max. Operating Pressure MPa (kgf/cm ²)	Max. Speed (r.p.m.)	Weight (with jaw) (kg)	Moment of Inertia I (kg·m ²)	Matching Cylinder
DR-08	10	7.2	25.4(2593)	45.4(4630)	2.5(2.5)	3000	25	0.035	MS125C

SPECIFICATIONS:

Model	Floating Plate stroke (mm)	Max. Operating Pressure MPa (kgf/cm ²)	Max. Speed (r.p.m.)	Weight (with jaw) (kg)	Moment of Inertia I (kg·m ²)	Matching Cylinder
P165	35	1.0(10)	6000	18.5	0.02	MF125C



HN SERIES
SPECIFICATIONS:
3-JAW EXTRA HIGH SPEED THROUGH - HOLE POWER CHUCK (WITH ADAPTOR)

- 1. Possible 10,000 r.p.m. highest speed chuck.
- 2. Model HN chucks are assembled with adaptor for ASA B5.9 type A spindles.
- 3. Model HN chucks are manufactured from high grade alloy steel. All sliding surfaces are hardened and ground for accurate actual running and long service repeatability.

GRIPPING CHARACTERISTIC GRAPH

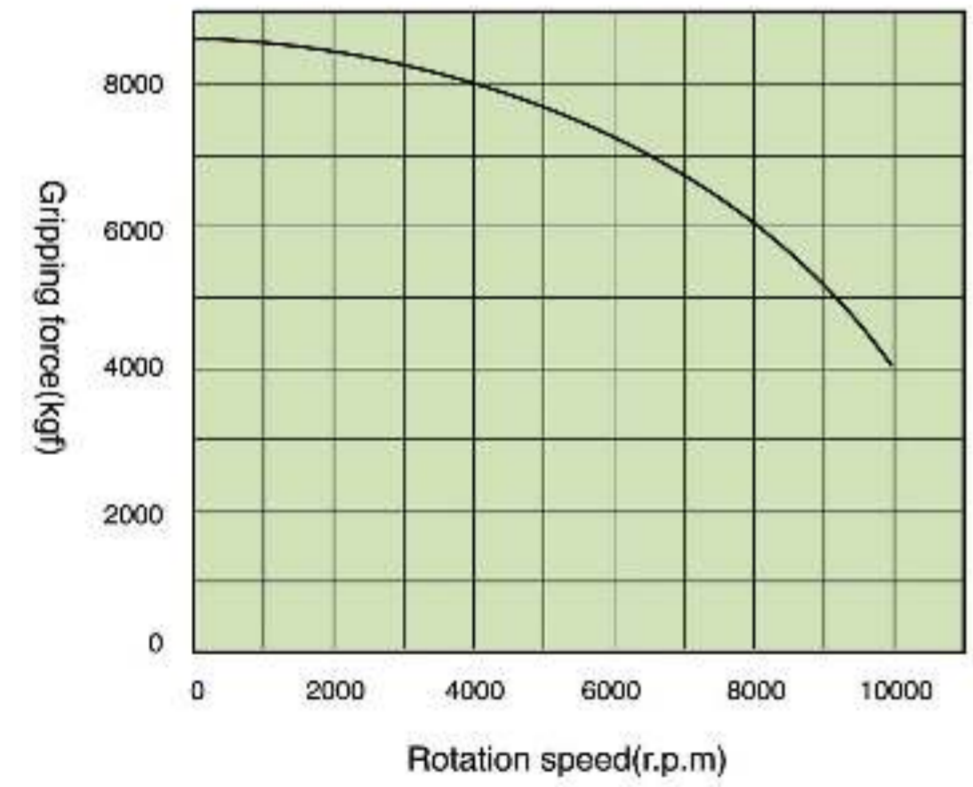

SPECIFICATIONS:

Model	Through-Hole(mm)	Plunger Stroke (mm)	Jaw Stroke (in dia) (mm)	Max.Draw Bar Pull Force KN (kgf)	Max.Gripping Force KN (kgf)	Max.Operating Pressure KN (kgf/cm ²)	Max. Speed (r.p.m.)	Weight (Kg)	Moment of Inertia I (kg·m ²)	Matching Cylinder	Matching Soft Jaw	Gripping O.D. Range (mm)
HN-06	∅36	12	5.5	30(3050)	79.4(8100)	2.9(30)	10000	11.5	0.035	HG-1336	Model-A	∅14-∅51